

# GENERAL MICROBIOLOGY LAB MANUAL



*Pakpour & Horgan*  
California State University  
East Bay

California State University East Bay  
General Microbiology Lab Manual

Pakpour & Horgan

This text is disseminated via the Open Education Resource (OER) LibreTexts Project (<https://LibreTexts.org>) and like the hundreds of other texts available within this powerful platform, it is freely available for reading, printing and "consuming." Most, but not all, pages in the library have licenses that may allow individuals to make changes, save, and print this book. Carefully consult the applicable license(s) before pursuing such effects.

Instructors can adopt existing LibreTexts texts or Remix them to quickly build course-specific resources to meet the needs of their students. Unlike traditional textbooks, LibreTexts' web based origins allow powerful integration of advanced features and new technologies to support learning.



The LibreTexts mission is to unite students, faculty and scholars in a cooperative effort to develop an easy-to-use online platform for the construction, customization, and dissemination of OER content to reduce the burdens of unreasonable textbook costs to our students and society. The LibreTexts project is a multi-institutional collaborative venture to develop the next generation of open-access texts to improve postsecondary education at all levels of higher learning by developing an Open Access Resource environment. The project currently consists of 14 independently operating and interconnected libraries that are constantly being optimized by students, faculty, and outside experts to supplant conventional paper-based books. These free textbook alternatives are organized within a central environment that is both vertically (from advance to basic level) and horizontally (across different fields) integrated.

The LibreTexts libraries are Powered by [NICE CXOne](#) and are supported by the Department of Education Open Textbook Pilot Project, the UC Davis Office of the Provost, the UC Davis Library, the California State University Affordable Learning Solutions Program, and Merlot. This material is based upon work supported by the National Science Foundation under Grant No. 1246120, 1525057, and 1413739.

Any opinions, findings, and conclusions or recommendations expressed in this material are those of the author(s) and do not necessarily reflect the views of the National Science Foundation nor the US Department of Education.

Have questions or comments? For information about adoptions or adaptations contact [info@LibreTexts.org](mailto:info@LibreTexts.org). More information on our activities can be found via Facebook (<https://facebook.com/Libretexts>), Twitter (<https://twitter.com/libretexts>), or our blog (<http://Blog.Libretexts.org>).

This text was compiled on 11/05/2023

# TABLE OF CONTENTS

Licensing

Introduction

Laboratory and Safety Rules

Lab 1: The Microscopic World

- Lab 1: Worksheet

Lab 2: Aseptic Technique

- Lab 2: Worksheet

Lab 3: Simple, Negative, and Gram Stain

- Lab 3: Worksheet

Lab 4: Acid-Fast, Spores, and Capsule Stains

- Lab 4: Worksheet

Lab 5: Pipette and Environmental Requirements

- Lab 5: Worksheet

Lab 6: Antibiotic Susceptibility Testing

- Lab 6: Worksheet

Lab 7: Sterilization

- Lab 7: Worksheet

Lab 8: Membrane Filtration

- Lab 8: Worksheet

Lab 9: Standard Plate Count

- Lab 9: Worksheet

Lab 10: Plaque Assay and Biochemical Tests (Day 1)

- Lab 10: Worksheet

Lab 11: Biochemical Tests (Day 2)

- Lab 11: Data Sheet

## Lab 12: Staphylococcus and Streptococcus

- [Lab 12: Worksheet](#)

## Lab 13: ELISA

- [Lab 13: Worksheet](#)

[Index](#)

[Glossary](#)

[Detailed Licensing](#)

## Licensing

---

A detailed breakdown of this resource's licensing can be found in [Back Matter/Detailed Licensing](#).

## Introduction

---

Microbiology laboratory is designed to allow students to grow, characterize, and identify many bacteria. The laboratory sessions will expose you to many potential pathogenic bacteria and listed below are many of the genera of bacteria that we will use during the laboratory sessions.

Please consult your physician AND INFORM THE INSTRUCTOR if you have a medical condition, including but not limited to being HIV positive, having an autoimmune disease, being an organ transplant recipient, undergoing cancer treatments, being pregnant, or any other medical conditions that might be a concern. If you have such a condition, we can take appropriate steps to accommodate your health situation.

### Note

Genera we may work with including but are not limited to:

*Staphylococcus*, *Streptococcus*, *Enterococcus*, *Escherichia*, *Bacillus*, *Listeria*, *Erysipelothrix*, *Coryne*, *Mycobacterium*, *Citrobacter*, *Klebsiella*, *Proteus*, *Shigella*, *Providencia*, *Yersinia*, *Vibrio*, *Campylobacter*, *Aeromonas*, *Plesiomonas*, *Acinetobacter*, *Stenotrophomonas*, *Shewanella*, *Alcaligenes*, *Neisseria*, *Haemophilus*, *Legionella*, *Bordetella*, *Pasteurella*, *Clostridium*

---

This page titled [Introduction](#) is shared under a [CC BY-SA](#) license and was authored, remixed, and/or curated by [Nazy Pakpour & Sharon Horgan](#).

## Laboratory and Safety Rules

Laboratory safety regulations will be strictly enforced. Repeated infractions will result in points lost. All organisms will be considered pathogenic, and should be handled with aseptic technique and universal precautions when working in the laboratory.

1. Wash your hands with soap and water before entering or leaving the lab.

2. Wear shoes that completely cover your feet, you cannot wear sandals or other open-toe OR open-heel shoes (clogs are ok).

3. You must wear a lab coat when working in the microbiology lab. You must store your lab coat/shirt in the lab. Your lab coat/shirt may NOT be removed from the room during the semester.

4. Long hair must be tied back in a ponytail, all hats must be removed or turned backward.

5. Accidents or injuries must be reported to your instructor as soon as possible. Know the location of the fire blanket, fire extinguisher, shower and eyewash in case of emergency.

6. Do not eat, drink, or chew gum in the lab. Avoid hand-to-mouth activities such as nail biting or chewing on the end of a pencil/pen.

7. Cell phones are not allowed in lab under any circumstances.

8. Do not put paper towels used to wipe down the bench in the bench top waste baskets.

9. Bunsen burners should never be left unattended

10. Disinfect your lab space at the start and end of each lab period. To disinfect your area wipe down the table top thoroughly with laboratory disinfectant and a paper towel. When leaving the lab, apply disinfectant to the bench area and leave to air dry (wet).

11. Remove any non-essential materials from your lab workspace, and keep only what you need for conducting the laboratory activity on your bench. Store coats and backpacks where they will not be in the way.

12. At the end of the lab period return all equipment to its place of origin. It is important that we maintain/improve our surroundings for other classes/students.

13. Dispose of wastes as instructed. Hazardous chemicals and microbial cultures must be properly discarded in designated containers and kill areas. We will inform you of the proper disposal procedures. Do not discard any materials that have contacted microbial cultures or hazardous chemicals in sinks or wastebaskets.

14. Treat each other with respect, you are all here to learn, you are all going to make lots of mistakes, be patient with each other.



This page titled [Laboratory and Safety Rules](#) is shared under a [CC BY-SA](#) license and was authored, remixed, and/or curated by [Nazy Pakpour & Sharon Horgan](#).

## Lab 1: The Microscopic World

### ACTIVITY 1: Getting to Know Your Microscope

1. Individually, get the combination from the instructor for your microscope drawer.
2. Open combination drawer and take out the microscope.
3. Label all the parts of the microscope with the provided post-its using the image below or the laboratory manual.

#### Note

The image below does not match your microscope perfectly, you will be responsible for knowing the parts of your microscope on the lab practical.

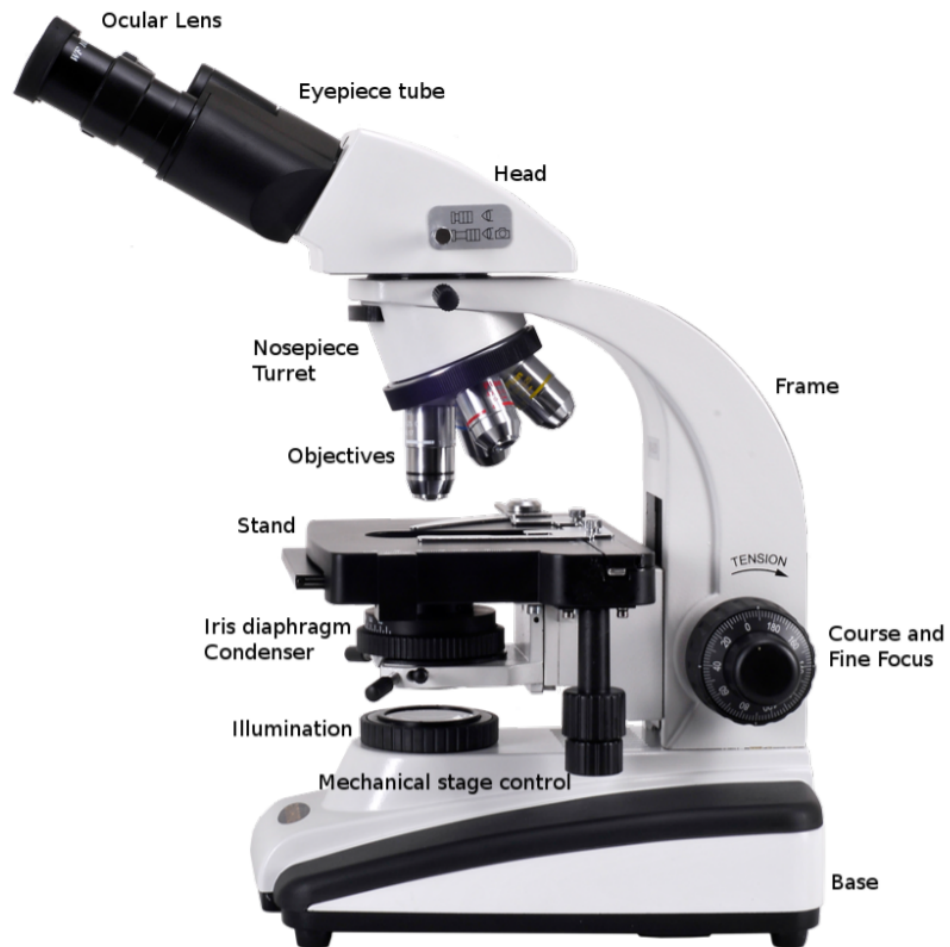

#### Practice worksheet (this is not an assignment)

Can you label all the parts of the microscope?



Complete the following:

The magnification is = \_\_\_\_\_ multiplied by \_\_\_\_\_

Ocular	Objective	Total Magnification

## ACTIVITY 2: How to Use Your Microscope

### Note

Microscope magnification: enlarging an object's appearance

The magnification is = (power of the oculars) multiplied by (power of the objectives)

Our microscopes have 10X oculars and 4X, 10X, 40X and 100X objectives

Never carry a microscope with just one hand!

### FOCUSING:

1. Use one of the pre-made, gram-stained, bacterial slides.
2. Make sure the condenser is all the way up and the iris diaphragm is all the way open, letting the maximum amount of light to contact your slide.
3. ALWAYS start at 4X, stage lowered, focus with coarse focus knob first.

4. Once in focus move to 10X and focus using the **fine** focus knob.
5. Once in focus move to 40X and focus using the **fine** focus knob.
6. Move objectives half-way between 40X and 100X, add 1 drop of oil.
7. **MAKE SURE THE 40X DOES NOT TOUCH THE OIL!**
8. Move to 100x and SLOWLY focus with the fine focus knob If you do not see your image clearly, DO NOT go back to the 40X and try to refocus.



### CLEANING A MICROSCOPE:

1. Lower stage.
2. Remove slide, turn the power off.
3. Wipe oil from all surfaces and 100X with lens paper.
4. With the second piece of lens paper, moistened with alcohol, wipe all surfaces. Never use Kimwipes to clean microscope.
5. Wipe surfaces with a new dry piece of lens paper.
6. Return to the lowest lens (4x).



Once you are ready, invite the instructor over for your first skill tests.

#### SKILL TEST #1 (2.5 PTS): FOCUSING MICROSCOPE

Under the supervision of the instructor or lab technician, bring your slide into focus under 100X. You can use your notes, books, etc. but you CAN NOT get help from other students.

#### SKILL TEST #2 (2.5 pts): Cleaning your microscope

Under the supervision of the instructor or lab technician, clean your microscope. You can use your notes, books, etc. but you CAN NOT get help from other students.

### PLEASE READ THE FOLLOWING BEFORE PROCEEDING:

**Stentors** are a genus of single-celled eukaryotic organisms with cilia. They are usually horn-shaped and are among the biggest known unicellular organisms. They reproduce asexually through binary fission and are found in most freshwater lakes and streams.

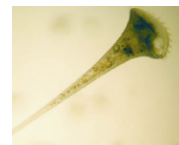

**Paramecia** are a genus of single-celled eukaryotic organisms with cilia. They are usually oval shaped and were some of the first microorganisms studied under a microscope. They reproduce asexually through binary fission and are found in freshwater, brackish, and marine environments.

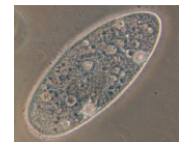

**Euglenas** are a genus of single-celled eukaryotic organisms with flagella. They are cylindrical with bright green chloroplasts inside. They are found in fresh and salt waters. Even though they have the ability to photosynthesize (like plants) they can also feed on other organisms (like animals).

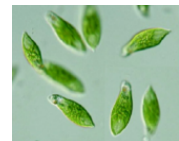

**Giardia lamblia** is a single-celled eukaryotic parasitic organism. The flagellated form of the parasite colonizes and reproduces in the small intestine, causing giardiasis. *Giardia* trophozoites absorb their nutrients from the lumen of the small intestine and are anaerobes (do not use oxygen). Human infection occurs via ingestion of water contaminated with the dormant cyst form of the parasite or through fecal-oral contamination. The cyst form is very hardy and can survive for weeks to months in cold water, and are resistant to chlorination. *Giardia* infects humans but is also one of the most common parasites infecting cats, dogs, cattle, sheep, and birds. The life cycle begins with a cyst being excreted in the feces of an infected individual. A distinguishing characteristic of the cyst is four nuclei. Once ingested by a host, the trophozoite emerges from the cyst.

This is the active stage of the parasite capable of feeding and movement. After the feeding stage, the trophozoite undergoes asexual replication through longitudinal binary fission. The resulting trophozoites and cysts then pass through the digestive system in the feces. While the trophozoites may be found in the feces, only the cysts are capable of surviving outside of the host.

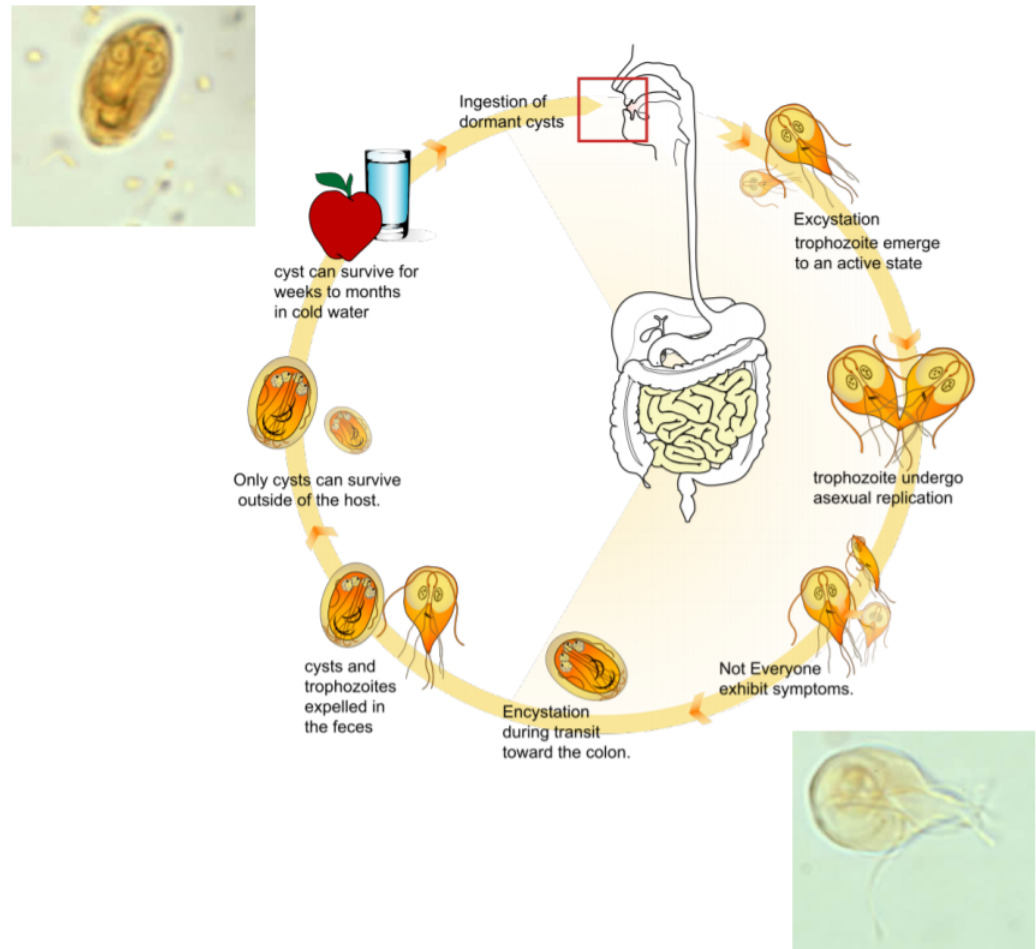

AFTER you have completed your skill tests, examine each of the following slides and sketch the organism you observe below.

1. Stentor
2. Paramecium
3. Euglena
4. *Giardia* cyst and trophozoite

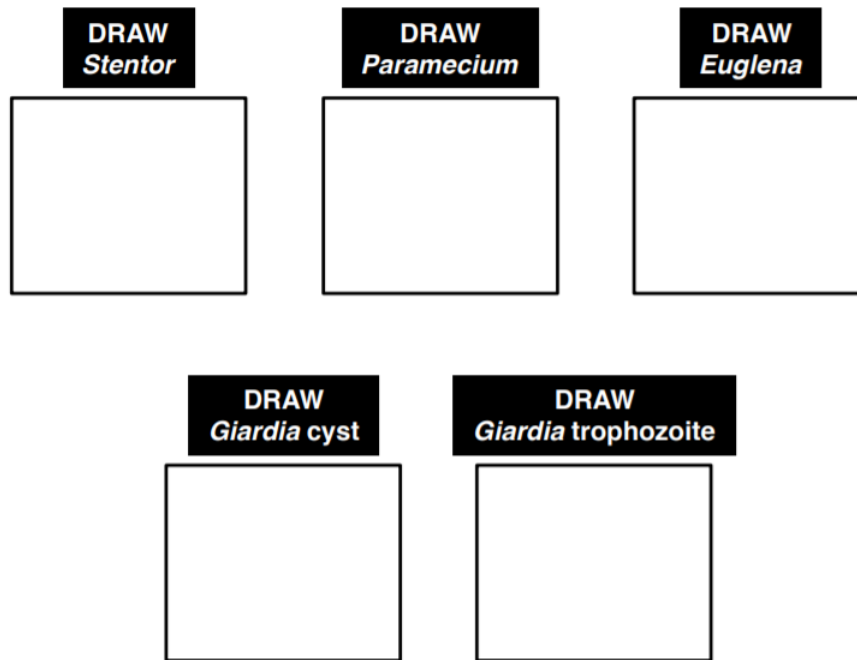

### ACTIVITY 3 (with your lab partner):

1. Label 5 TSA plates.
2. Place plate #1 within 6 inches of Bunsen burner open for 2 min.
3. Place plate #2 FAR away from Bunsen burner open for 2 min.
4. Place plate #3 FAR away from Bunsen burner open for 10 min.
5. Place plate #4 FAR away from Bunsen burner open for 30 min.
6. Take plate #5 and use a wet swab (use the sterile water to wet) to swab something (your partner, outside, your nose, be creative).
7. Take one touch plate and touch one place (face, walls, floor, shoes, bathrooms... be creative).
8. Put all your plates in the 37°C incubator, make sure your plates are agar side up.

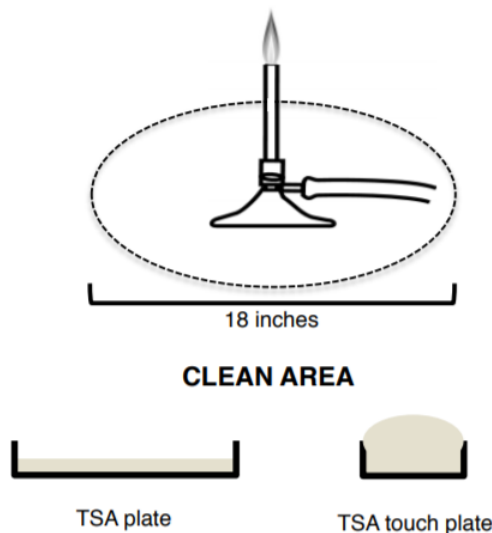

## Trypticase soy agar (TSA)

Trypticase soy agar (TSA) is a growth medium for the culturing of bacteria. It is one of the most common general-purpose media used in microbiology labs. TSA provides enough nutrients to allow for a wide variety of microorganisms to grow and is used for storage (4°C), enumeration (counting), isolation of pure cultures, or just general culturing. TSA contains enzymatic digests of casein and soybean meal, which provides amino acids and other nitrogenous substances, making it a nutritious medium for a variety of organisms. Glucose is the energy source. Sodium chloride maintains the osmotic equilibrium, while dipotassium phosphate acts as a buffer to maintain pH. Agar is used as a gelling agent.

Sometimes the medium is supplemented with blood to facilitate the growth of more fastidious bacteria or antimicrobial agents (antibiotics) to permit the selection of various microbial groups. TSA is frequently the base media of other agar plate types. For example, blood agar plates (BAP) are made by enriching TSA plates with defibrinated sheep blood, while chocolate agar is made through additional cooking of BAP.

### HOW TO LABEL SAMPLES:

In microbiology, it is important to properly label the media plates, broths, or slants **PRIOR** to inoculation with different microorganisms to avoid contamination.

Label your samples with a SHARPIE with the following information:

1. Your name or initials or group name
2. Date
3. Medium type
4. Organism name or abbreviation
5. Temperature that plate/tube will be incubated at
6. Miscellaneous info (antibiotic, time point, etc.)

**Always label the  
BOTTOM of plate  
(bottom = side w/agar)**

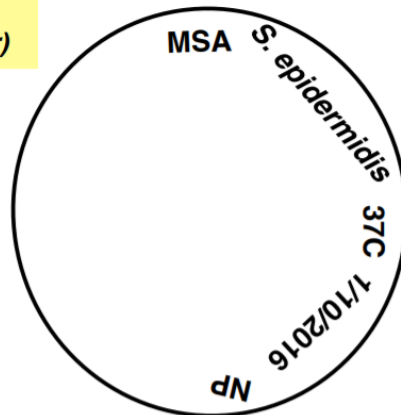

**Always label tube BELOW  
where the cap/lid sits**

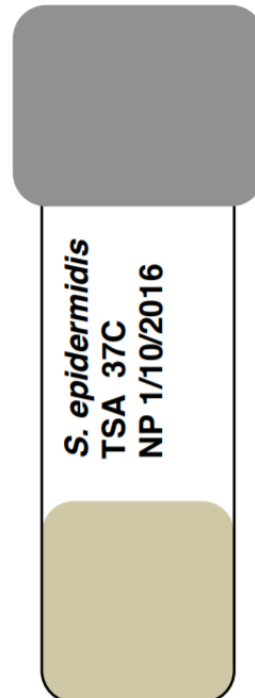

**Always label slides with  
PENCIL!**

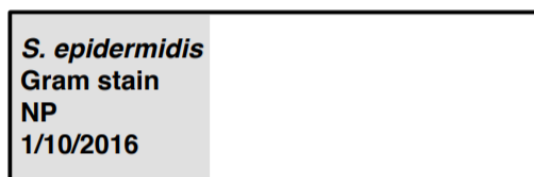

This page titled [Lab 1: The Microscopic World](#) is shared under a [CC BY-SA](#) license and was authored, remixed, and/or curated by [Nazzy Pakpour & Sharon Horgan](#).

## Lab 1: Worksheet

Name: \_\_\_\_\_

Section: \_\_\_\_\_

Student ID#: \_\_\_\_\_

Work in groups on these problems. You should try to answer the questions without referring to your textbook. If you get stuck, try asking another group for help.

1. What are two differences between the cyst and trophozoite form of Giardia? (1)
2. List two things the person in this picture is doing wrong. (1)



3. What are the energy sources of organisms in the genus Euglena? (0.5)

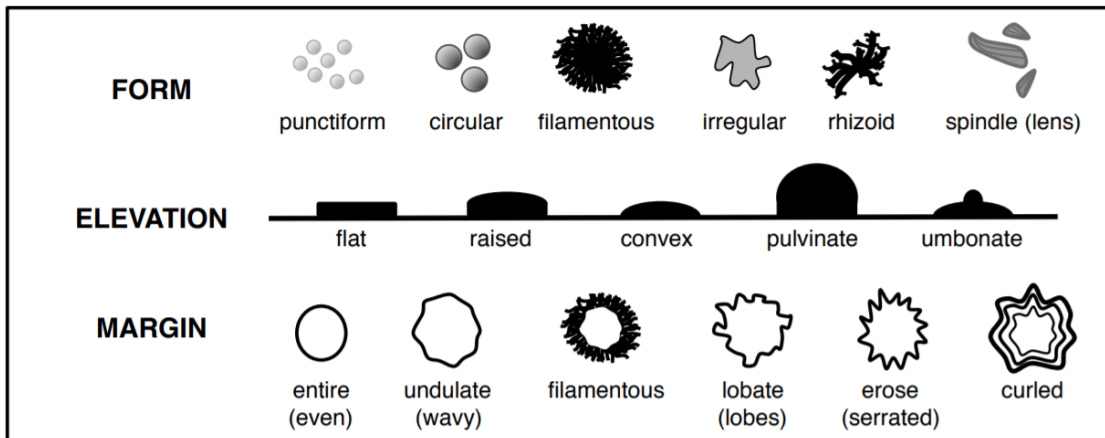

4. Using the figure above, describe the form, elevation, and margins of two different colonies on your touch plate. (1)
5. Of the plates placed open for different amounts of time which had the least growth, which had the most growth, and why? (2)

This page titled [Lab 1: Worksheet](#) is shared under a [CC BY-SA](#) license and was authored, remixed, and/or curated by [Nazy Pakpour & Sharon Horgan](#).

## Lab 2: Aseptic Technique

You will be working with many pathogenic species of bacteria in the laboratory. Remember that bacteria are in the air as well as on the skin, the counter, and all objects and equipment that have not been sterilized. The most important tool for transferring cultures is the wire inoculating needle or loop. It can be quickly sterilized by heating it to red hot in a Bunsen burner flame. Adjust the air inlets of the burner so that there are a hotter inner cone and the cooler outer flame. A dry needle may be sterilized by holding it at a 30-degree angle in the outer part of the flame. A wet loop with bacteria on it should first be held in the inner part of the flame to avoid spattering, and then heated until red hot in the outer part of the flame. Always flame the loop immediately before and after use! Allow it to cool before picking up an inoculum of bacteria (or you will kill the bacteria). Hold the loop or wire handle like a pencil.

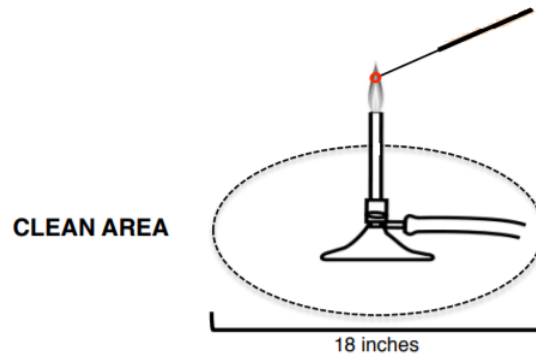

### Remember to:

1. Always stand or carry tubes in a rack.
2. Not lay the cap down or touch anything with it.
3. Not remove the lid unnecessarily or for prolonged periods of time.
4. Always put the lid of plates face down.

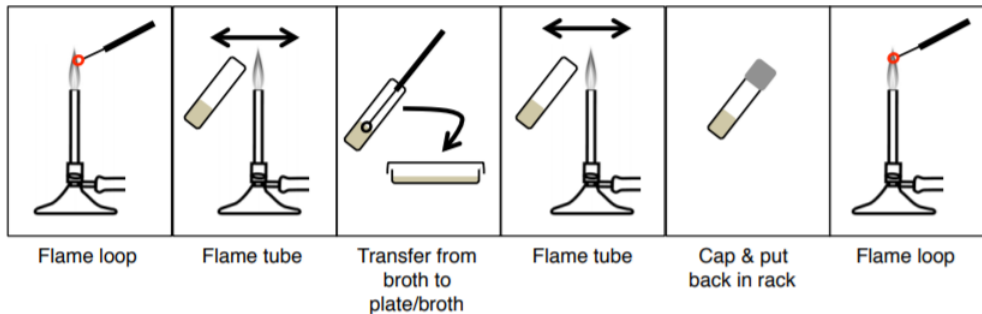

### How To Streak For Isolated Colonies (SFIC):

Mixed cultures (more than one species) can be isolated using the streak plate technique. The goal is to acquire a pure culture of one species of bacteria, in a single colony, from a mixed culture. We do this by separating the microbes on the surface of agar with quadrant streaking, this method DILUTES the bacteria. The goal is not to have bacteria in all four quadrants but rather to get single isolated colonies.

### Exercise

Practice SFIC by using your pencil instead of the loop. Once you put your pencil down in the 'plate', don't lift it again. Make sure to flame between each quadrant.

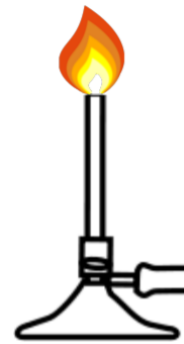
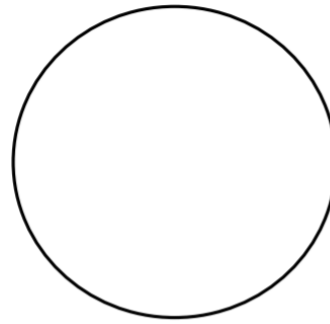
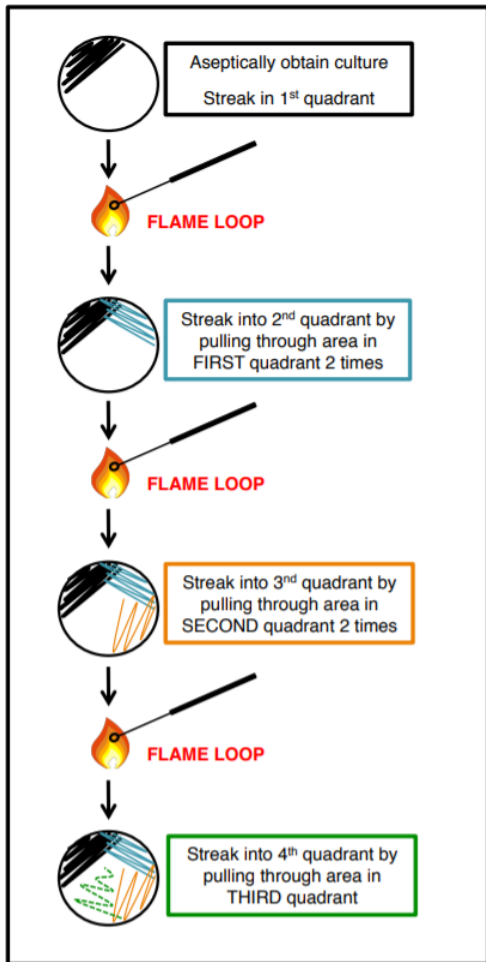

Different Types Of Media For Bacterial Growth:

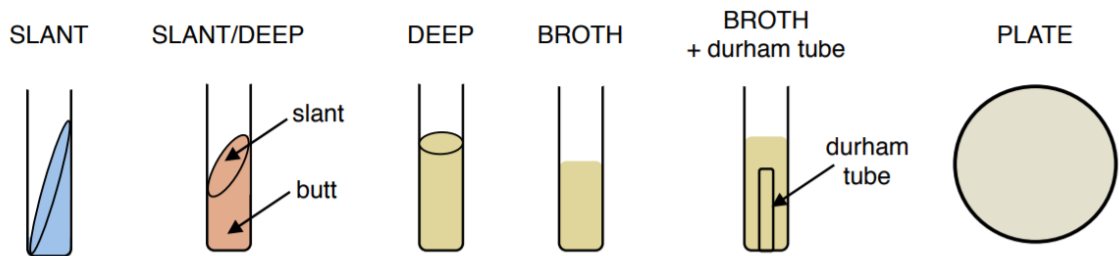

**SLANT:** solid medium made with agar and various nutrients and indicators. Slanting gives the bacteria a greater surface area on which to grow in a tube. Agar slants are also useful in maintaining bacterial cultures, more so than stacks of Petri dishes. Multiple cultures are easily placed into test tube racks and stored under refrigeration. Bacteria are inoculated onto a slant using a loop and grow in the surface of the agar.

**SLANT/DEEP:** solid medium made with agar and various nutrients and indicators. Similar to a slant but creates a deep zone, commonly called the 'butt'. This type of culture medium gives the ability to grow bacteria in both an aerobic, oxygen-rich, environment (surface of the slant) and an anaerobic, oxygen deficient, environment (butt of slant). Slant/deeps are inoculated by stabbing a needle into the butt and then immediately streaking across the surface of the slant.

**DEEP:** solid medium made with agar and various nutrients and indicators. This type of culture is used for the growth of anaerobic bacteria which grow in the absence of oxygen and are inoculated by stabbing the media with a needle.

**BROTH:** liquid medium made with various nutrients and indicators. Allows for the growth of large volumes of bacteria, the level of growth can be assessed based on the turbidity (cloudiness) of the culture. Bacteria are inoculated into a broth using a loop.

**BROTH+DURHAM TUBE:** liquid medium made with various nutrients and indicators in which an upside-down smaller tube, called a Durham tube, is placed. Durham tubes are used to detect the production of gases, such as CO<sub>2</sub> or N<sub>2</sub>, by microorganisms. The tube is initially filled with the medium and then collects gas as the bacteria grow, creating a bubble. Bacteria are inoculated into a broth+Durham tube using a loop.

**PLATE:** solid medium made with agar and various nutrients and indicators. Can be made in Petri dishes of various sizes. Plates are particularly helpful in isolating a specific species of bacteria, which is not possible in a liquid medium. Using the SFIC technique bacteria can be diluted until individual colonies are formed. Bacteria are inoculated onto a plate using a loop

#### Note

Please be aware that a loop will collect much higher concentrations of bacteria from a plate than from a broth. Therefore, when using the SFIC technique please consider what media/medium you are taking the bacteria from.

### Aseptic Transfer Of Bacteria:

FOR THIS LAB YOU WILL BE WORKING INDIVIDUALLY

1. You will be provided with *Staphylococcus epidermidis* in a broth and on a plate. These will be shared with the table and will be found at the front of each table in a white plastic rack.
2. Label 2 broth tubes, 2 slant tubes, and 2 plates.
3. Aseptically transfer bacteria from your BROTH culture to a broth, a slant, and a plate using your loop.

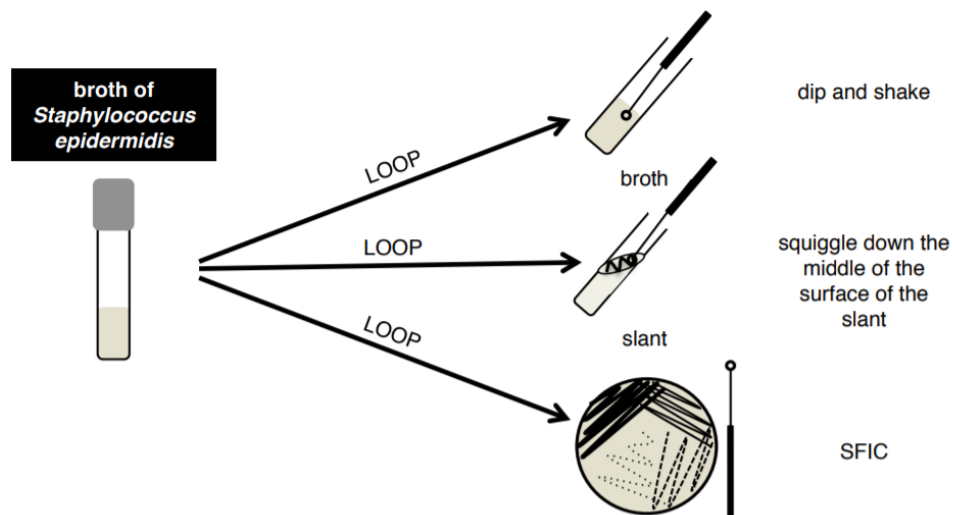

#### Note

There will be a skills test on SFIC and & future extra credit opportunities will be based on this technique, make sure you know how to do it!!

4. Aseptically transfer bacteria from your PLATE culture to a broth, a slant, and a plate
5. Plates will be placed in the 37°C incubator in the container labeled with your lab section. All tubes will be placed in the provided racks at the end of your table. When your table is done, one of you will need to place that rack in the 37°C incubator. (if you have read all the way to the last step before you started inoculating, write your name on a post-it and bring it to the instructor for 1 pt. extra credit)

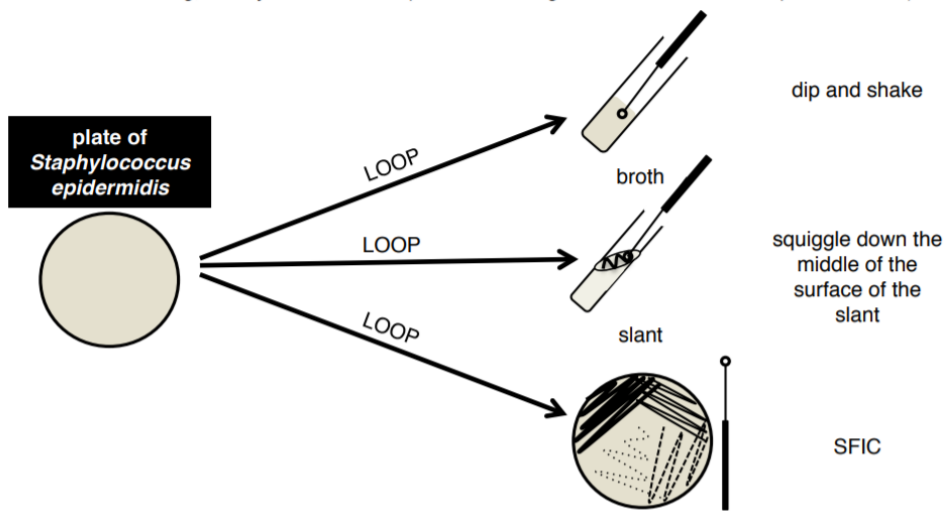

### Bacterial Shape and Arrangement:

Bacteria are described by three basic criteria: size, shape, and arrangement. The units used to measure organisms seen under a microscope are micrometers ( $\mu\text{m}$ ). A micrometer is one-millionth of a meter. Most microbes are around  $1\ \mu\text{m}$  in size. Viruses are typically  $1/10$  that size. Animal cells are typically around  $10\ \mu\text{m}$  in size. The three most common shapes are the rod (bacillus), the sphere (coccus), and the spiral type (vibrio).

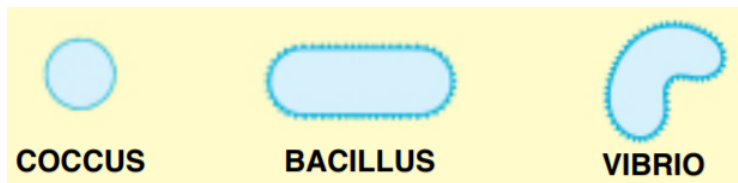

Arrangement is the manner by which groups of bacteria appear together. Some common arrangement types are paired (diplo), grape-like clusters (staphylo) or chains (strepto).

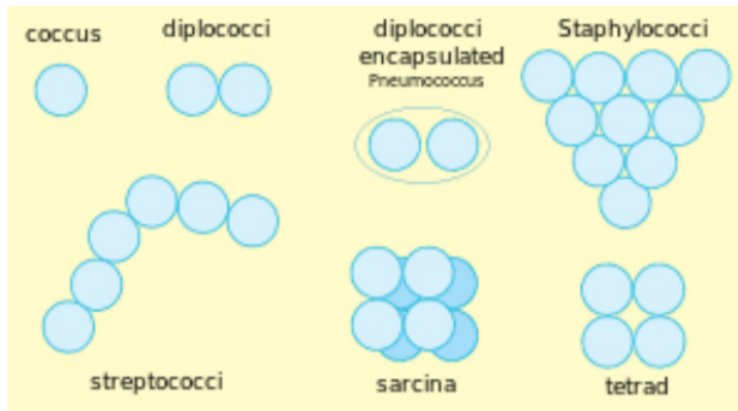

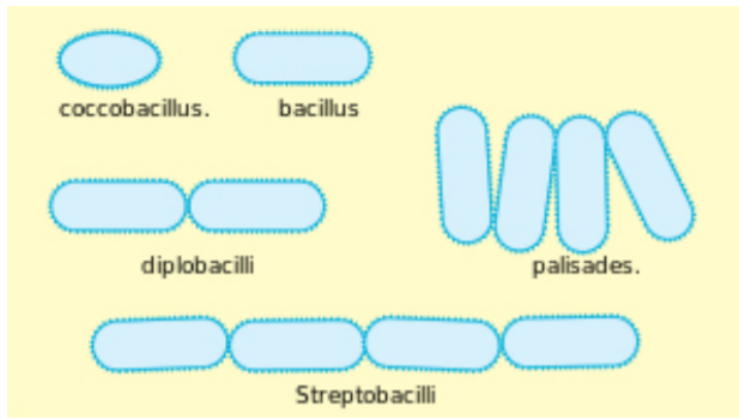

This page titled [Lab 2: Aseptic Technique](#) is shared under a [CC BY-SA](#) license and was authored, remixed, and/or curated by [Nazzy Pakpour & Sharon Horgan](#).

## Lab 2: Worksheet

---

Name: \_\_\_\_\_

Section: \_\_\_\_\_

Student ID#: \_\_\_\_\_

Work in groups on these problems. You should try to answer the questions without referring to your textbook. If you get stuck, try asking another group for help.

1. Did you inoculate your broth, slant, and plate properly? How do you know? (0.5)
2. What is aseptic technique and why do we use it? (1)
3. You inoculate a plate from a plate, you see no growth the next day. You know the plate had live bacteria on it. What went wrong? (1)
4. What is a Durham tube and what do we use it for? (1)
5. What is the difference between a slant and a slant/deep? (0.5) NOTE: do not just define the two terms, write an actual sentence describing the difference.
6. Which plate, the one inoculated from a broth or the one from a plate, would you expect to see more bacteria on? Why? (1)

---

This page titled [Lab 2: Worksheet](#) is shared under a [CC BY-SA](#) license and was authored, remixed, and/or curated by [Nazzy Pakpour & Sharon Horgan](#).

## Lab 3: Simple, Negative, and Gram Stain

### PREPARING AN EMULSION:

1. Working in pairs, label each slide and draw a circle on the center of the slide with a wax pencil which is provided at your table, DO NOT use a sharpie, this will keep the bacteria concentrated in one area on the slide.
2. Prepare an emulsion on each slide:
  - If you are taking a bacteria from a plate, place a small drop of water on a slide and aseptically add bacteria.
  - If you are taking a bacteria from a broth, place 3-6 loopfuls of bacteria onto a slide with no water added.
3. You and your lab partner will need to prepare the following slides:
  - 3 slides of *Staphylococcus epidermidis* (one for simple stain, one for gram stain, one as back-up)
  - 3 slides of *Pseudomonas aeruginosa* (one for simple stain, one for gram stain, one as back-up)
  - 2 slides of *S. epidermidis* and *P. aeruginosa* mixed together (one for gram stain, one as back-up)
4. Mix gently until you get an even cloudy mixture (should look like skim milk)

#### Note

If you mix too aggressively, you will lose the bacterial morphology.

5. Allow the slide(s) to air dry on the slide warmer. While the slides are drying, start your negative stain.
6. Once the liquid has completely evaporated, heat fix by passing the slide through a flame three times.

#### Note

If you heat fix too little, the bacteria will wash off the slide. If you heat fix too much, you will cook the bacteria and denature them.

7. Allow the slide to cool and then continue with your staining protocol.

### NEGATIVE STAIN:

#### Definition

Nigrosin is a simple and indirect stain used for determining bacterial morphology. The shapes and sizes of the organisms are seen as color-free outlines against the dark background. An advantage of using this method is that prior fixation by heat is not needed, so the organisms are seen in more lifelike shapes. Nigrosin is an acidic stain which becomes negatively charged. Since the surface of most bacterial cells is negatively charged, the cell surface repels the stain. The glass of the slide will stain, but the bacterial cells will not.

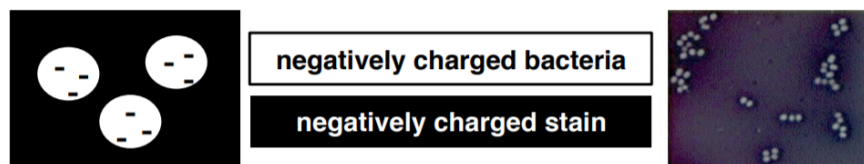

8. If you need to, step outside and watch this video to make sure you understand how to do the procedure: [www.youtube.com/watch?v=avveXgPWVJ8](https://www.youtube.com/watch?v=avveXgPWVJ8) (you can also google “negative stain video”)
9. Add a small drop of nigrosin to the slide.
10. Aseptically transfer one loopful of your NEGATIVE STAIN MIX bacteria into the drop of nigrosin and mix gently.
11. Use a second slide, held at a 45-degree angle to smear across your slide.
12. Allow the slides to air dry on the counter. Do not use slide warmer!

13. Repeat this procedure to make a slide of *S. epidermidis* and a slide of *P. aeruginosa* 14. Examine all three slides under oil immersion and record your results on your worksheet.

### SIMPLE STAIN:

#### Definition

Methylene blue is a simple and direct stain used for determining bacterial morphology (shape and arrangement). It is a cationic dye (positive charge) which stains the cell a blue color. The presence of negatively charged molecules in the cell (like DNA & RNA) causes the cell to stain blue.

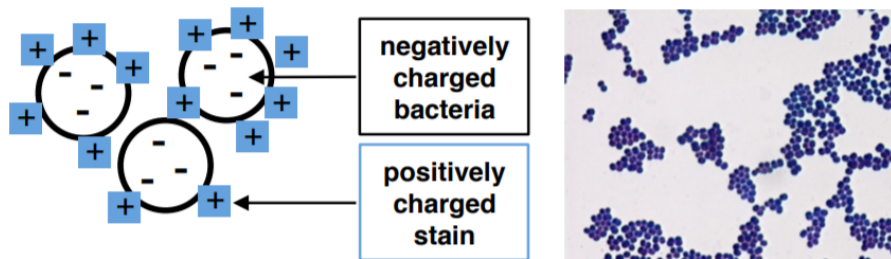

15. Use the slides that you already prepared.
16. Add Methylene blue stain to heat-fixed slide and leave for 2 minutes.
17. Hold the slide in an angle and rinse gently with water from the squirt bottle.
18. Blot gently with bibulous paper to get rid of excess water.
19. Examine under oil immersion and record your results on your worksheet.

### GRAM STAIN:

#### Definition

The Gram stain is the most important and universally used staining technique in the bacteriology laboratory. It is used to distinguish between gram (+) and gram (-) bacteria. The difference between gram (+) and gram (-) bacteria lies in the ability of the cell wall of the organism to retain the crystal violet.

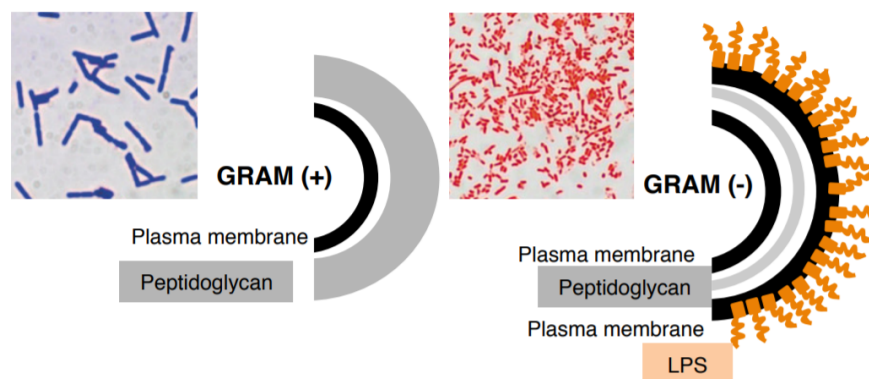

18. Use the slides that you already prepared (1) *S. epidermidis* (2) *P. aeruginosa* (3) *S. epidermidis* and *P. aeruginosa* mixed together.
19. Stain with crystal violet for 1 minute, then rinse gently with water.
20. Treat with iodine mixture for 1 minute, then rinse gently with water.
21. Rinse with ~3-6 drops of 95% alcohol to decolorize, then rinse gently with water.

22. Counterstain with safranin for 30 seconds, then rinse with water.

**Note**

Proper gram stains of the mixed culture are worth 2 points extra credit!

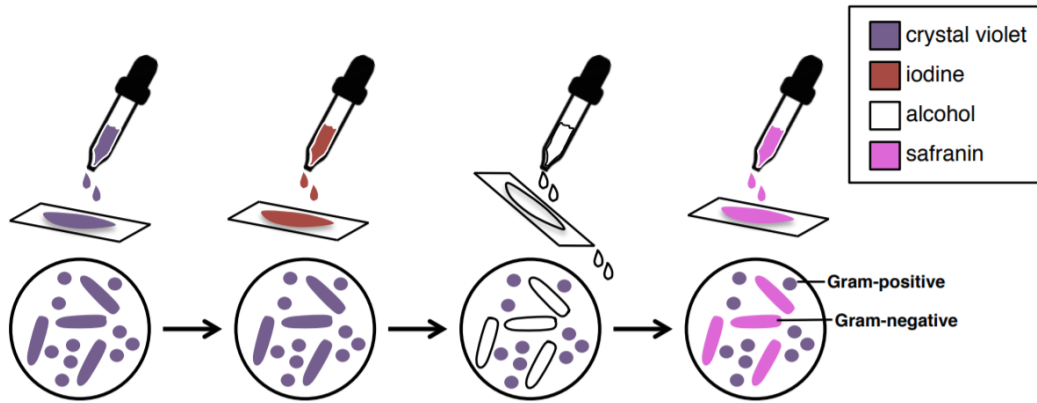

**common mistakes**

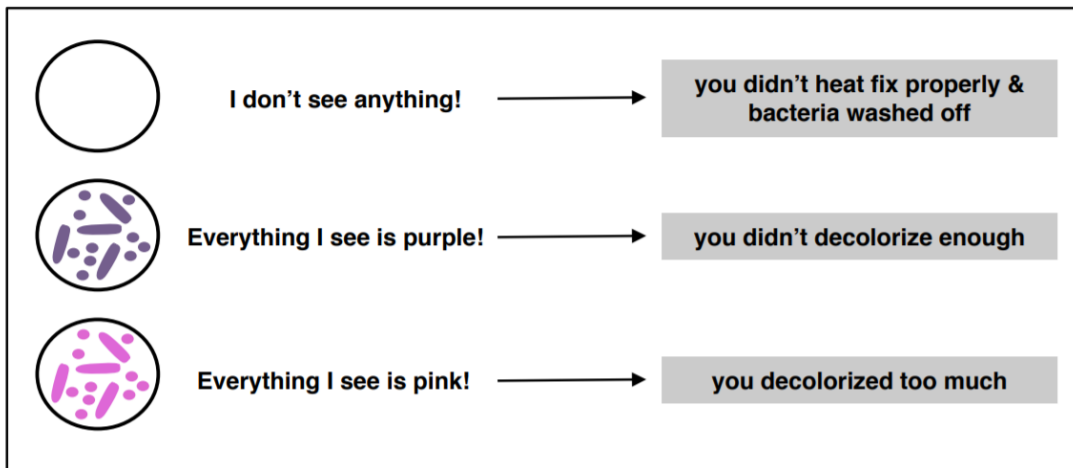

This page titled [Lab 3: Simple, Negative, and Gram Stain](#) is shared under a [CC BY-SA](#) license and was authored, remixed, and/or curated by [Nazy Pakpour & Sharon Horgan](#).





## Lab 3: Worksheet

Name: \_\_\_\_\_



Section: \_\_\_\_\_

Student ID#: \_\_\_\_\_

Work in groups on these problems. You should try to answer the questions without referring to your textbook. If you get stuck, try asking another group for help.

<b>DRAW simple stain</b>	<b>DRAW simple stain</b>	
		
<b>DRAW negative stain</b>	<b>DRAW negative stain</b>	<b>DRAW negative stain</b>
		
<i>S. epidermidis</i>	<i>P. aeruginosa</i>	<i>S. epidermidis and P. aeruginosa</i>

1. Why are *S. epidermidis* and *P. aeruginosa* the same color with the simple stain? (1)
2. What is being stained in a negative stain? (1)
3. How does the charge of bacterial cells impact the staining procedures used? (1)

<b>DRAW gram stain</b>	<b>DRAW gram stain</b>	<b>DRAW gram stain</b>
		
<i>S. epidermidis</i>	<i>P. aeruginosa</i>	<i>S. epidermidis and P. aeruginosa</i>

4. Which plate had gram-negative bacteria? What color were these bacteria and why? (2)
5. Which plate had gram-positive bacteria? What color were they and why? (2)
6. Draw the membrane layers of a gram-positive and gram-negative bacteria making sure to label the plasma membrane, peptidoglycan layers, periplasmic space, and LPS (3)

---

This page titled [Lab 3: Worksheet](#) is shared under a [CC BY-SA](#) license and was authored, remixed, and/or curated by [Nazzy Pakpour & Sharon Horgan](#).

## Lab 4: Acid-Fast, Spores, and Capsule Stains

### ACID-FAST

Acid-fast stain is a differential stain used to identify acid-fast organisms such as members of the genus *Mycobacterium*. Acid-fast organisms are characterized by wax-like, nearly impermeable cell walls; they contain mycolic acid and large amounts of fatty acids, waxes, and complex lipids. This type of cell wall is resistant to most compounds, therefore acid-fast organisms require a special staining technique.

The primary stain used in acid-fast staining, carbol fuchsin, is lipid-soluble and contains phenol, which helps the stain penetrate the cell wall. This is further assisted by the addition of heat in the form of heat (steam). Steam helps to loosen up the waxy layer and promotes entry of the primary stain inside the cell. The smear is then rinsed with a very strong decolorizer, which strips the stain from all non-acid-fast cells but does not permeate the cell wall of acid-fast organisms. The decolorized non-acid-fast cells then take up the counterstain, which in our case is methylene blue.

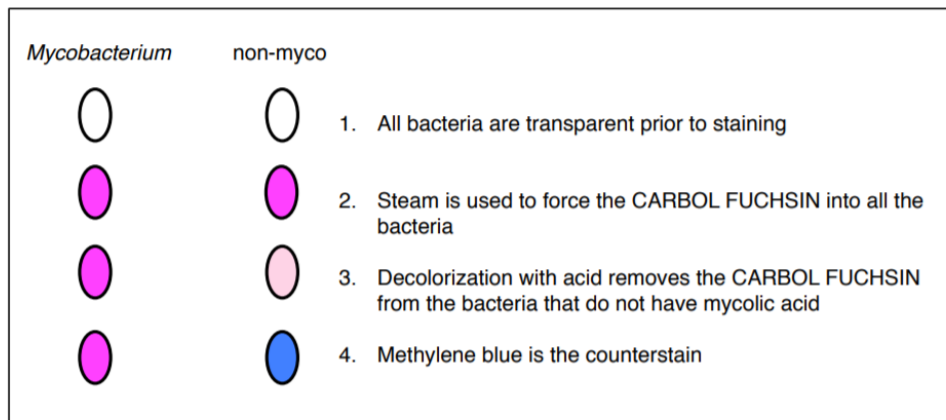
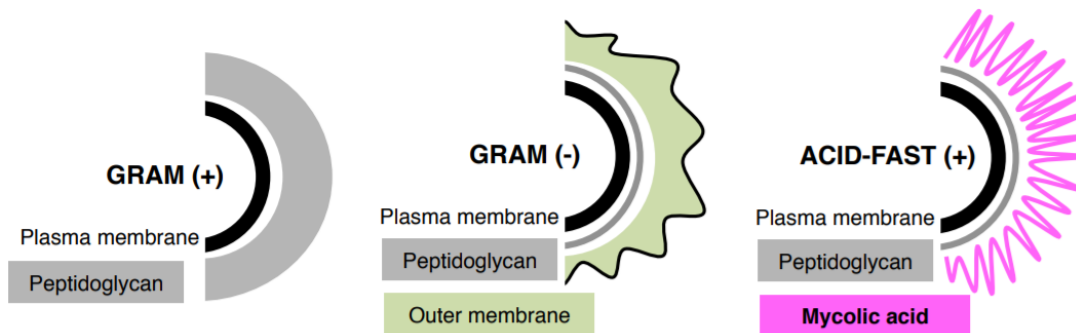

1. Working in pairs, prepare THREE slides as directed below (2 for back-up and one to stain).
2. Label each slide and draw a circle on the center of the slide with a wax pencil.
3. Prepare an emulsion on each slide with 4 loopfuls of *Staphylococcus epidermidis* from your broth culture onto the slide (these will be your acid-fast negative bacteria).
4. Then, add one loopful of *Mycobacterium chelonae* (these are your acid fast positive bacteria) and mix the two bacteria together.
5. Allow the slide(s) to air dry on the slide warmers (while these slides are drying, prepare your slides for the spore stain).
6. Once the liquid has completely evaporated, heat fix the bacteria by passing it through your flame three times.
7. Make sure the slide rack on top of your beaker is completely level. Then, bring your water to boil while the slides are drying.

You only need about 200 milliliters of water. If you add more, you will be waiting all lab period for your water to boil.

8. Once the water is boiling, place your slide on the slide rack above the boiling water.
9. Cover the area of your smear on the slide with a square piece of PRECUT paper towel. Make sure none of the paper is hanging off the slide.
10. Carefully apply the CARBOL FUCHSIN stain to the paper towel.

If a stain appears in the water you are boiling, please stop and discard the stained water in the liquid waste disposal. The fumes from carbol fuchsin can be toxic.

11. Steam with the stain on the slide for 7 minutes while continuously applying more stain so the paper square never dries out.
12. Gently remove the paper with forceps and discard it in the small waste paper cup that will be provided on your bench. Then, rinse the slide with water.
13. Put the slide on your staining basin and gently rinse with water.
14. Decolorize with 6 drops of acid alcohol (not ethanol from your gram stain kit), then rinse with water.
15. Counterstain with methylene blue for 2 minutes.
16. Rinse with water and blot dry with bibulous paper (do not use the slide warmer).
17. Examine under the 100X objective lens with oil immersion and record your results.

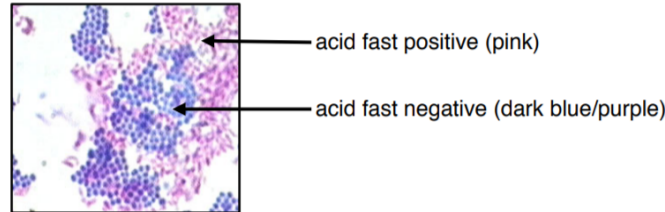

The colors of this image may be slightly off due to printing/copying.

## SPORE STAIN

The endospore stain is a differential stain used to visualize bacterial endospores. An endospore is a dormant form of a bacterium, which some species of bacteria produce under stressful conditions such as poor nutrition, high temperatures, or dry environments. The outer layer is composed of keratin which resists staining. The malachite-green stain is forced into the spore using steam. Spores can be central, terminal, and subterminal. This stain is commonly used to detect spores produced from the genera of *Bacillus* and *Clostridium*.

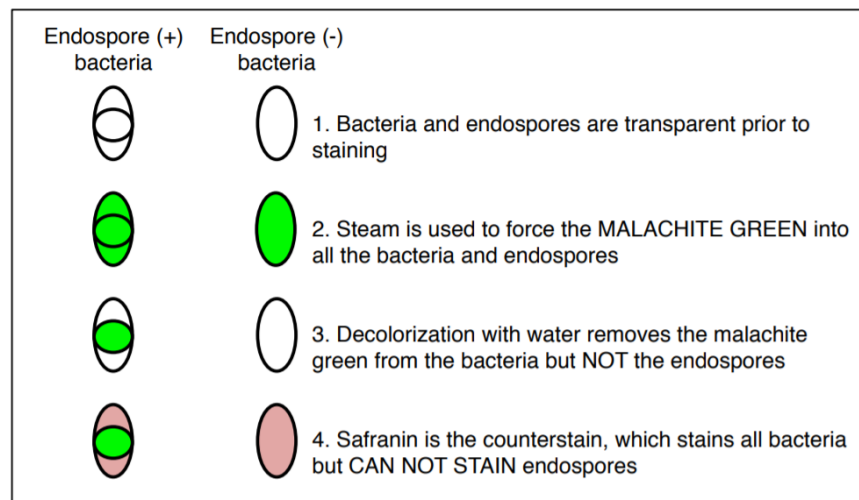

18. Prepare two slides with emulsions one from plate A and one from plate B.

19. Heat fix the slides and place them on the slide rack above the boiling water.
20. Cover the area of your smear on each slide with a square piece of PRECUT paper towel.
21. Carefully apply the MALACHITE GREEN stain to the paper towel.
22. Steam for 10 minutes and keep the paper soaked with the stain during this time.
23. Gently remove the paper with forceps, discard in the small waste paper cup that will be provided on your bench, and then rinse the slide with water.
24. Put the slides on your staining basin and gently rinse with water.
25. Counterstain with SAFRANIN for 1 minute and then rinse with water. Blot dry with bibulous paper.
26. Examine under the 100X objective lens with oil immersion and record your results.



The colors of this image may be slightly off due to printing/copying.

## CAPSULE STAIN

Most capsules are composed of polysaccharides or polypeptides which are a thick, detectable, and discrete layer outside the cell wall. Some capsules have well-defined boundaries while some have fuzzy, trailing edges. Capsules protect bacteria from the phagocytic action of immune cells and allow pathogens to invade the body. If a pathogen loses its ability to form capsules, it often ceases to be pathogenic.

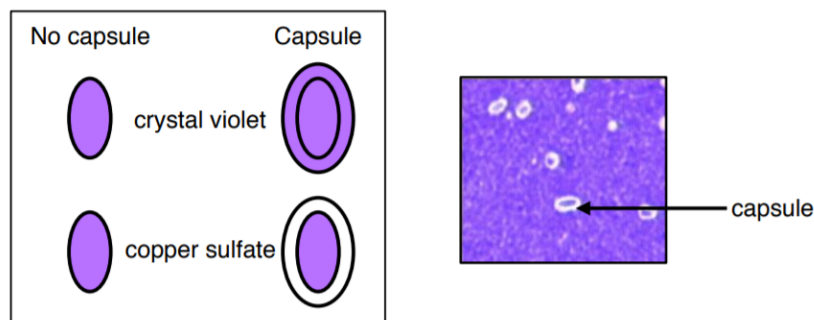

27. Label and prepare a slide with an emulsion of *Klebsiella pneumoniae*.
28. Let it air dry (DO NOT USE THE SLIDE WARMER, DO NOT HEAT FIX).
29. Stain with 1% crystal violet for 2 minutes (DO NOT USE CRYSTAL VIOLET FROM GRAM STAIN).
30. VERY GENTLY rinse with 6 drops of copper sulfate.
31. Let it air dry on the counter (do not use slide warmer).
32. Examine under the 100X objective lens with oil immersion and record your results.

This page titled [Lab 4: Acid-Fast, Spores, and Capsule Stains](#) is shared under a [CC BY-SA](#) license and was authored, remixed, and/or curated by [Nazy Pakpour & Sharon Horgan](#).

## Lab 4: Worksheet

---

Name: \_\_\_\_\_

Section: \_\_\_\_\_

Student ID#: \_\_\_\_\_

Work in groups on these problems. You should try to answer the questions without referring to your textbook. If you get stuck, try asking another group for help.

**DRAW**  
acid fast stain



1. Label which bacteria are Staphylococcus and which are Mycobacterium. (2)

2. Why is it important to steam the slides for an acid fast stain? (1)

**DRAW**  
spore stain

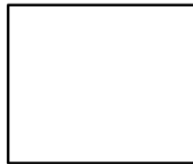

plate A

**DRAW**  
spore stain

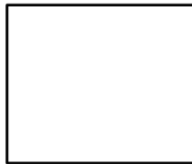
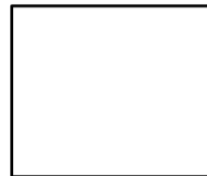

plate B

3. One of your plates contained manganese which is known to induce the sporulation of Bacillus, which plate was it? (3)

4. Draw what you would expect to see for plate A and B if you did not counterstain with safranin. (1)

**DRAW**  
capsule stain



5. Why did you not heat fix this slide? (2)

6. How does the presence of a capsule make a bacteria potentially more pathogenic to us? (1)

---

This page titled [Lab 4: Worksheet](#) is shared under a [CC BY-SA](#) license and was authored, remixed, and/or curated by [Nazy Pakpour & Sharon Horgan](#).

## Lab 5: Pipette and Environmental Requirements

### Getting to Know Your Pipette:

1. Find the following parts on your pipette:

- Volume adjustment dial
- Tip ejector button
- Plunger button
- Stainless steel micrometer
- Digital volume indicator
- Stainless steel ejector arm (removable)
- Plastic shaft
- Disposable yellow or blue tip

2. Practice holding your pipette correctly, placing a tip on our pipette, and ejected the tip. Do this at least three times.

3. The total volume a pipette can hold is stated on the top of the plunger. We will be working with the following three volume pipettes:

- P-20 0.02  $\mu\text{l}$  – 20  $\mu\text{l}$
- P-200 20  $\mu\text{l}$  – 200  $\mu\text{l}$
- P-1000 200  $\mu\text{l}$  – 1000  $\mu\text{l}$

4. Based on the volume pipette you have the numbers in the digital display have a different meaning.

P20			P200			P1000		
min.	int.	max.	min.	int.	max.	min.	int.	max.
0	1	2	0	1	2	0	0	1
2	2	0	5	2	0	2	7	0
0	5	0	0	5	0	0	5	0
2 $\mu\text{l}$	12.5 $\mu\text{l}$	20 $\mu\text{l}$	50 $\mu\text{l}$	125 $\mu\text{l}$	200 $\mu\text{l}$	200 $\mu\text{l}$	750 $\mu\text{l}$	1000 $\mu\text{l}$

5. Rotate the volume adjustment knob until the digital indicator reaches the desired volume, then place a disposable tip on the shaft of the pipette (practice all three volumes min, int, max)

6. Press down on the plunger to the First Stop. (You will be able to push past this point, but there is enough resistance to stop the movement if you try to be aware of it.)

7. Hold the pipette vertically and immerse the disposable tip into the sample. Use the colored water and the microcentrifuge tubes provided to you.

8. Allow the plunger button to return slowly to its original position. Do not allow the button to snap up.

9. To dispense the sample: place the tip against the side wall of the receiving tube and push the plunger down to the first stop. Wait 2-3 seconds, then depress the plunger to the second stop in order to expel any residual sample in the tip.

10. While the plunger is still pushed down, remove the pipette from the tube and allow the plunger to slowly return to its original position.

11. Practice until you are ready and then call an instructor for your skills test. This skills test is worth 5 points.

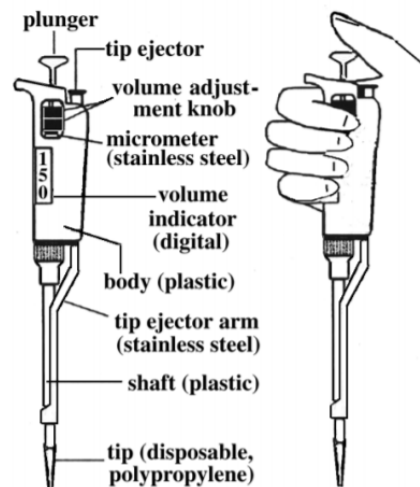

#### Warning

- Never rotate the volume adjustment knob past the upper or lower range of the pipetman.
- Never lay the pipetman down on its side or hold it horizontally when it contains liquid.
- Never immerse the shaft of the pipetman into the fluid.

## Environmental Requirements (Temperature)

### How does temperature affect bacterial growth?

Organisms grow best over a certain temperature range, and this range has restrictions. The cardinal temperatures are the range of temperatures over which an organism can grow. Every organism has evolved to live at a particular optimum temperature.

- Minimum: lowest temp where reproduction occurs
- Maximum: highest temp where reproduction occurs
- Optimum: highest rate of reproduction

Organisms are classified based on the temperature ranges they live in:

- Psychrophiles: less than zero
- Psychrotrophs: 0-30°C
- Mesophiles: middle temperatures 15-45°C
- Thermophiles: 40-80°C
- Extreme Thermophiles: above 65°C

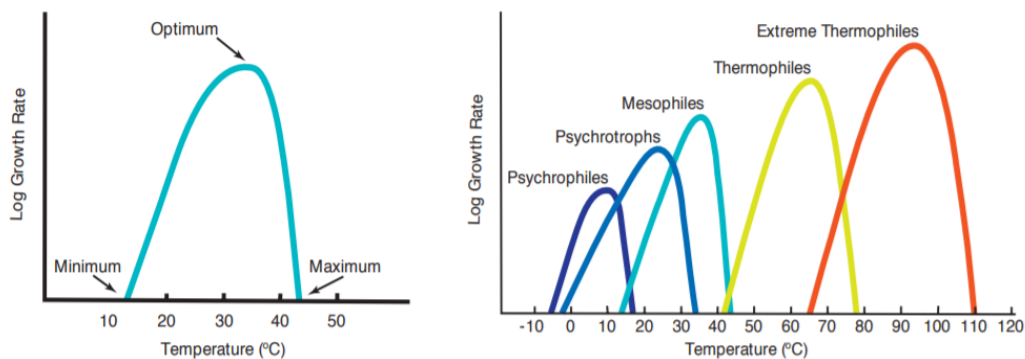

### WHAT ARE THE CARDINAL TEMPERATURES OF 3 DIFFERENT ORGANISMS?

1. Working as a table you will need 15 Tryptic Soy Broth (TSB) tubes.
2. Label your broth tubes with the bacterial species (3 species) and temperature (5 temps) = 15 tubes:
  - Escherichia coli (5 broth tubes)
  - Geobacillus stearothermophilus (5 broth tubes)
  - Pseudomonas fluorescens (5 broth tubes)
3. Mix each broth culture before using by gently tapping on the tube.
4. Using aseptic technique, use a sterile pipette to transfer 20 µl of each organism to appropriate test tube of broth.

#### Note

If you are not consistent with the volume you inoculate, your results will be undesirable.

5. Place all in the provided racks at the end of your table. When your table is done, one of you will need to place your rack in the 37°C incubator.
6. Each person at your table will streak for isolated colonies from a broth of *Serratia marcescens* onto a TSA plate.
7. Three people will incubate their plate at 30°C and the other half at 40°C. Containers for the plates will be placed on the instructor's desk.

## Environmental Requirements (pH)

### How does pH affect bacterial growth?

Hydrogen ions in a solution = pH. Organisms grow best at a specific pH range based, in part, on the environment they have evolved to live in. If bacteria are outside their optimal pH range their proteins can become denatured. Ranges of pH over which an organism can live place them in groups:

- Acidophiles: below pH 5.5
- Neutrophiles: pH 5.5 -8.5
- Alkaliphiles: pH above 8.5

solution classification	pH	H <sup>+</sup> concentration (moles/liter)	common examples	organismal classification
↑ <b>ACIDIC</b>	0	10 <sup>0</sup>	nitric acid	↑ <b>acidophiles</b>
	1	10 <sup>-1</sup>	stomach acid	
	2	10 <sup>-2</sup>	lemon juice	
	3	10 <sup>-3</sup>	vinegar, soda	
	4	10 <sup>-4</sup>	tomatoes, orange juice	
<b>NEUTRAL</b>	5	10 <sup>-5</sup>	black coffee	<b>neutrophiles</b>
	6	10 <sup>-6</sup>	urine	
↓ <b>ALKALINE</b>	7	10 <sup>-7</sup>	pure water	↓ <b>alkaliphiles</b>
	8	10 <sup>-8</sup>	seawater	
	9	10 <sup>-9</sup>	baking soda	
	10	10 <sup>-10</sup>	soap	
	11	10 <sup>-11</sup>	ammonia	
	12	10 <sup>-12</sup>	lime water	
	13	10 <sup>-13</sup>	household bleach	
	14	10 <sup>-14</sup>	drain cleaner	

### WHAT ARE THE pH RANGES OF 3 DIFFERENT ORGANISMS?

8. Working as a table you will need 15 TSB tubes of the following pHs:

- 3 tubes of pH 2
- 3 tubes of pH 4
- 3 tubes of pH 6
- 3 tubes of pH 8
- 3 tubes of pH 10

9. Label your broth tubes with the bacterial species (3 species) and pH (5 pH) = 15 tubes

- *Lactobacillus plantarum* → pH 2, 4, 6, 8, 10
- *Staphylococcus saprophyticus* → pH 2, 4, 6, 8, 10
- *Alcaligenes faecalis* → pH 2, 4, 6, 8, 10

10. Mix the culture before using by gently tapping on the tube.

11. Using aseptic technique, use a sterile pipette to transfer 20 µl of each organism to appropriate test tube of broth.

12. Place all inoculated tubes in the provided racks at the end of your table. When your table is done, one of you will need to place that racks in the 37°C incubator.

### Environmental Requirements (Salinity)

#### How does osmotic pressure affect bacterial growth?

Water is essential to all organisms. The ability to control the movement of water across a membrane is necessary for the survival of all cells. Osmotic pressure is the minimum pressure which needs to be applied to a solution to prevent the inward flow of water across a semi-permeable membrane. The movement of water is controlled by the concentration of solutes contained within the water (usually salt). Bacteria can be classified based upon the salinity they can tolerate:

- Halophiles (prefer NaCl concentrations of 3% or higher)

- Extreme halophiles (prefer NaCl concentrations of 15%-25%)
- Xerophile (prefer low salt concentrations)

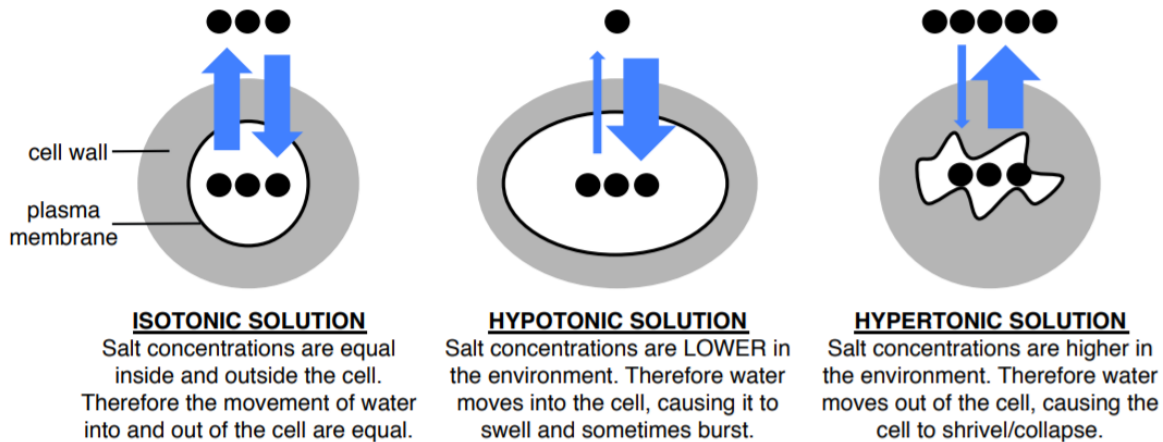

### WHAT ARE THE PREFERRED SALINITY RANGES OF 4 DIFFERENT ORGANISMS?

11. Working as a table you will need 28 TSB broths of the following salinities:

- 4 tubes of NaCl 0%
- 4 tubes of NaCl 2.5%
- 4 tubes of NaCl 5%
- 4 tubes of NaCl 10%
- 4 tubes of NaCl 15%
- 4 tubes of NaCl 20%
- 4 tubes of NaCl 25%

12. Label your broth tubes with the bacterial species (4 species) and salinity (7 concentrations) = 28 tubes:

- Escherichia coli
- Halobacterium salinarum
- Staphylococcus epidermidis
- Vibrio alginolyticus

13. Mix the culture before using by gently tapping on the tube.

14. Using aseptic technique, use a sterile pipette to transfer 20  $\mu$ l of each organism to appropriate test tube of broth.

15. Incubate E. coli and S. epidermidis at 37°C in the racks at your table, H. salinarum at 42°C, and V. alginolyticus at 30°C. These racks will be on the instructor's desk.

### Environmental Requirements (Aerotolerance)

#### What is aerotolerance and how does it affect bacterial growth?

Bacteria can differ dramatically in their ability to utilize oxygen ( $O_2$ ). Under aerobic conditions, oxygen acts as the final electron acceptor for the electron transport chain located in the plasma membrane of prokaryotes. Bacteria use this process to generate ATP, the energy source for most cellular processes. In the absence of oxygen ( $O_2$ ), some bacteria can use alternative metabolic pathways including anaerobic respiration and/or fermentation. During anaerobic respiration, other alternative molecules are used as the final electron acceptor for the electron transport chain such as nitrate ( $NO_3$ ), sulfate ( $SO_4$ ), and carbonate ( $CO_3$ ).

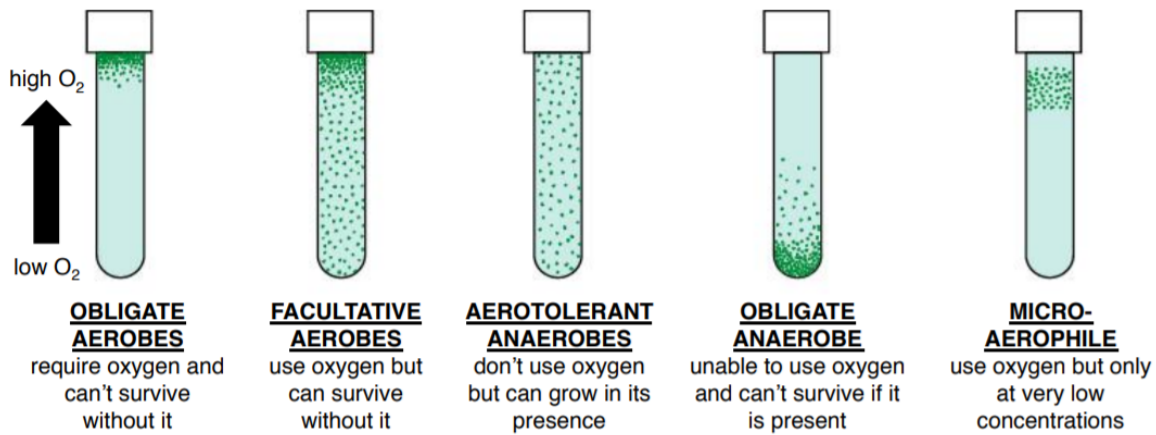

### WHAT IS THE AEROTOLERANCE OF THREE DIFFERENT SPECIES OF BACTERIA?

16. Working as a table you will need 2 yeast+glucose plates.

17. You will be using the following three bacterial species:

*Alcaligenes faecalis*

*Staphylococcus epidermidis*

*Clostridium sporogenes*

18. Divide both plates into three sections and aseptically transfer each bacteria species to a section, use your loop to draw a circle instead of streaking.

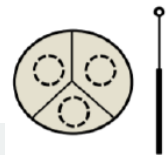

You will be comparing the growth between the three sections so make sure your streaks are of equal size.

19. One plate will be placed in a Torbal Jar at 37°C (anaerobic conditions) and one plate will just go directly in the incubator at 37°C (aerobic conditions). The Torbal jar will be at the end of each table.

### Environmental Requirements (Results):

#### How do we quantify bacterial growth?

Often in microbiology, we need to determine the number of bacterial cells in a broth. We can do this directly through spread plates (we will do this in a later lab) or indirectly by assessing the turbidity (cloudiness) of broth tubes. We measure turbidity using a spectrophotometer which gives us a reading of the light absorbance:

- more bacteria = more cloudy = higher absorbance
- less bacteria = less cloudy = lower absorbance

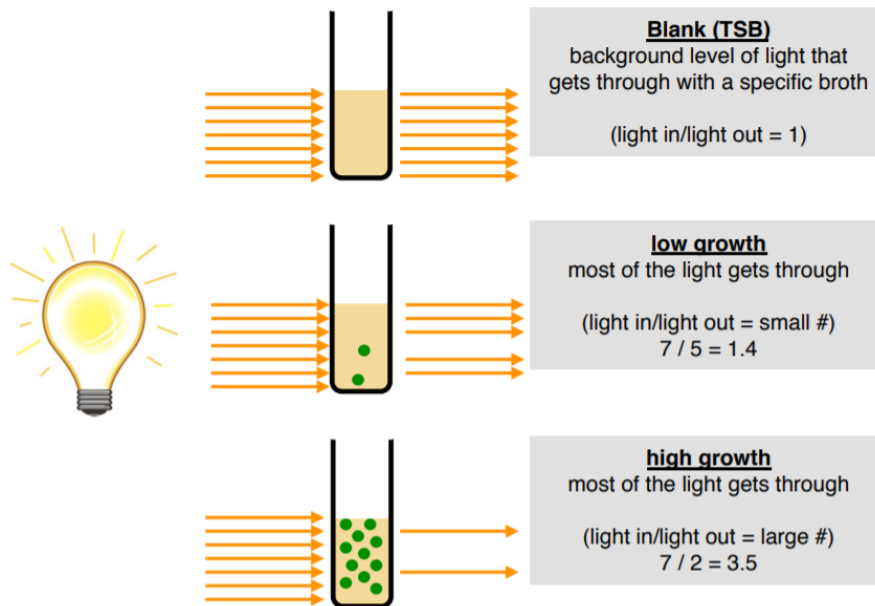

1. Make sure the screen of your spectrophotometer reads 600 nM followed by some set of numbers and then the letter A.
2. For the spectrophotometer reading, use a Kimwipe to wipe the outside of the “blank” tube. Each set of broths (temp, pH, salinity) will have their own blank tube
3. Place blank tube in the spectrophotometer, close the lid, and press the “0 ABS / 100% T” button. This will set the background level of absorbance present in the broth when there are no bacteria growing.
4. Remove the blank tube.
5. Mix each tube before using by gently tapping on the tube and wipe with Kimwipe.
6. Insert this tube into the spectrophotometer, and without pressing anything, record the absorbance.
7. Once you are finished add your data to the chart at the front of the class, you will need to copy the data for the entire class.
8. Calculate averages and standard deviation for each condition & make graphs for each bacteria per condition (refer to the example provided on page 36).

### Environmental Requirements (Graphs)

You will now graph the average and standard deviation of your **salinity data** on a computer on whatever graphing program you are familiar with. Please make sure your graph resembles the one below and shows the following information:

- graph title
- axis labels with units
- vertical error bars ONLY
- average at each salinity
- all FOUR species of bacteria on one graph

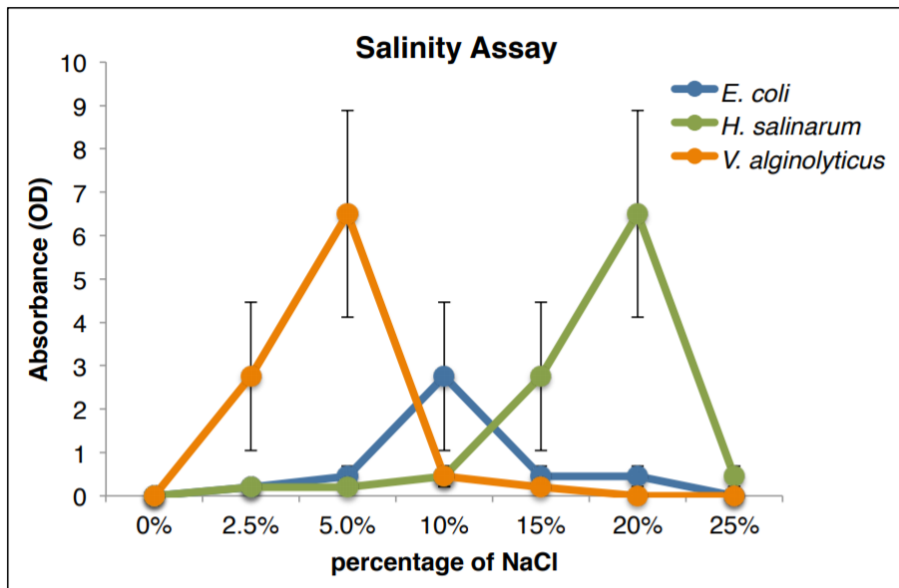

This page titled [Lab 5: Pipette and Environmental Requirements](#) is shared under a [CC BY-SA](#) license and was authored, remixed, and/or curated by [Nazzy Pakpour & Sharon Horgan](#).

## Lab 5: Worksheet

Name: \_\_\_\_\_

Section: \_\_\_\_\_

Student ID#: \_\_\_\_\_

Work in groups on these problems. You should try to answer the questions without referring to your textbook. If you get stuck, try asking another group for help.

1. Give the cardinal temperatures and descriptive group (page 31) for each bacterial species. (1.5)

*Escherichia coli* :

*Geobacillus stearothermophilus* :

*Pseudomonas fluorescens* :

2. Which bacterial species are acidophiles? (0.5)

3. Which bacterial species are extreme halophiles? (1)

4. Draw and label the growth on your plates. (1)

5. A sample from a patient suspected of being infected with *Clostridium difficile* is left out too long before being taken to the lab for identification. Why would that be a problem? (1)

### TEMPERATURE:

	<i>Escherichia coli</i>				
	10°C	20°C	30°C	40°C	50°C
Table 1					
Table 2					
Table 3					
Table 4					

	<i>Geobacillus stearothermophilus</i>				
	10°C	20°C	30°C	40°C	50°C
Table 1					
Table 2					
Table 3					
Table 4					

	<i>Pseudomonas fluorescens</i>				
	10°C	20°C	30°C	40°C	50°C
Table 1					
Table 2					
Table 3					
Table 4					

### pH:

	<i>Lactobacillus plantarum</i>

	pH 2	pH 4	pH 6	pH 8	pH 10
Table 1					
Table 2					
Table 3					
Table 4					

<i>Staphylococcus saprophyticus</i>					
	pH 2	pH 4	pH 6	pH 8	pH 10
Table 1					
Table 2					
Table 3					
Table 4					

<i>Alcaligenes faecalis</i>					
	pH 2	pH 4	pH 6	pH 8	pH 10
Table 1					
Table 2					
Table 3					
Table 4					

### SALINITY:

<i>Escherichia coli</i>							
	0%	2.5%	5%	10%	15%	20%	25%
Table 1							
Table 2							
Table 3							
Table 4							

<i>Halobacterium salinarum</i>							
	0%	2.5%	5%	10%	15%	20%	25%
Table 1							
Table 2							
Table 3							
Table 4							

<i>Vibrio alginolyticus</i>							
	0%	2.5%	5%	10%	15%	20%	25%
Table 1							
Table 2							
Table 3							
Table 4							

	<i>Staphylococcus epidermis</i>						
	0%	2.5%	5%	10%	15%	20%	25%
Table 1							
Table 2							
Table 3							
Table 4							

This page titled [Lab 5: Worksheet](#) is shared under a [CC BY-SA](#) license and was authored, remixed, and/or curated by [Nazy Pakpour & Sharon Horgan](#).

## Lab 6: Antibiotic Susceptibility Testing

In microbiology, McFarland standards are used as a reference to produce solutions that contain approximately similar numbers of bacteria for use in standardized microbial testing (Kirby Bauer). This is done by matching the turbidity (cloudiness) of McFarland standard with that of the test solution. Therefore it is important to always mix the McFarland standard before beginning. The standard can then be compared visually to a suspension of bacteria in sterile saline. If the bacterial suspension is too turbid, it can be diluted with more diluent. If the suspension is not turbid enough, more bacteria can be added.



McFarland used today will be 0.5 =  $\sim 1.5 \times 10^8$  CFU/mL.

### Definition



Mueller-Hinton Plate (MH Plate): A growth medium that is commonly used for antibiotic susceptibility testing and allows for even diffusion of the antibiotic in the medium. The Kirby-Bauer antimicrobial disk diffusion procedure is used with MH plates. The impregnated disk is placed on an agar surface, resulting in diffusion of the antimicrobial into the surrounding medium. Effectiveness of the antimicrobial can be shown by measuring the zone of inhibition (ZOI) for a pure culture of an organism.

### MAKING McFARLAND STANDARD

1. Working individually you will use a 0.5 McFarland Standard ( $1.5 \times 10^8$  CFU/mL) as a visual standard to make your own liquid standard from the plate provided to you (make sure to mix the standard tube before comparing turbidities).
2. Use a cotton swab to take a small amount of your bacteria from your plate and gently swirl it into your tube of saline until the turbidity matches that of your McFarland Standard.

Hold both tubes up to the light as you are swirling to best match the turbidity.

### KIRBY-BAUER

3. Create a full lawn from your liquid standard sample on Mueller-Hinton (MH) plate by dipping a new cotton swab ONCE into your McFarland Standard you have made and then swabbing a single plate 4X in four different directions.



4. Place your plate on the diagram on the handout.
5. Dip your forceps into the ethanol, flame BRIEFLY, and wait for all the ethanol to evaporate. Repeat this step 3 times.

In this procedure, it is the ethanol (not the heat) that disinfects the forceps. So, there is no need to hold the forceps in the flame for long periods of time.

6. Aseptically add the six standard antibiotics, incubate at 37°C.
7. Discard your saline tubes on the biohazard rack. DO NOT put them back with the unused saline!

The antibiotic discs are labeled; no additional labeling for the discs is necessary.

### MAKING ZONES OF INHIBITION:

1. Measure the diameter of zones of inhibition in mm. for each of your antibiotics and record your results below.
2. If you can't get the diameter because of an inadequate lawn or zones overlapping, measure the radius and multiply by 2.

3. Compare your results to the chart provided to determine if your bacterial species is resistant or susceptible to the antibiotics we used.

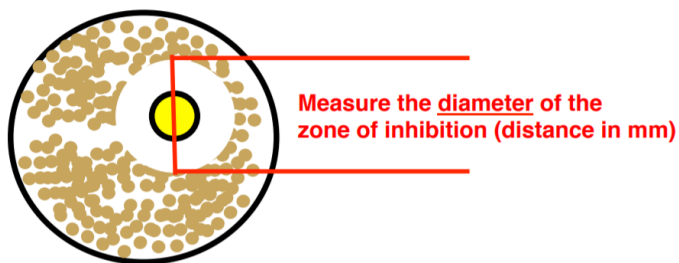

Bacterial Species: _____		
Antibiotic Species	ZOI	Resistant (R)/Susceptible (S)/Intermediate (I)
Penicillin (p10)		
Chloramphenicol (C30)		
Trimethoprim (TMP5)		
Ciprofloxacin (CIP5)		
Streptomycin (S10)		
Augmentin (AMC30)		

You do not need to turn in this sheet but you will need it to answer questions on the worksheet on the next page.

This page titled [Lab 6: Antibiotic Susceptibility Testing](#) is shared under a [CC BY-SA](#) license and was authored, remixed, and/or curated by [Nazy Pakpour & Sharon Horgan](#).

## Lab 6: Worksheet

---

Name: \_\_\_\_\_

Section: \_\_\_\_\_

Student ID#: \_\_\_\_\_

Work in groups on these problems. You should try to answer the questions without referring to your textbook. If you get stuck, try asking another group for help.

1. What is your bacterial species and what antibiotic should you definitely not use on a patient that is infected with your bacterial species? Why? (1)
  2. What antibiotic should you use on a patient that is infected with your bacterial species? Why? (1)
  3. Why do we use a Mueller-Hinton (MH) plate in this lab? (1)
  4. Why do we use a McFarland standard for this lab? (1)
  5. What would happen if you did not get a full lawn on your MH plate during this lab? (1)
- 

This page titled [Lab 6: Worksheet](#) is shared under a [CC BY-SA](#) license and was authored, remixed, and/or curated by [Nazy Pakpour & Sharon Horgan](#).

## Lab 7: Sterilization

### UV Radiation:

#### What effect does ultraviolet light exposure have on bacterial growth?

Ionizing radiation (e.g. x-rays, gamma radiation) carries enough energy to remove electrons from molecules in a cell. When electrons are removed from molecules, free radicals are formed that damage the cell leading to DNA damage, mutations, and cell death. Non-ionizing radiation, such as ultraviolet (UV) light, excites electrons in molecules. The excitation of electrons in DNA molecules often results in the formation of extra bonds between adjacent pyrimidines (specifically thymine) in DNA. When two pyrimidines are bound together in this way, it is called a pyrimidine dimer. These dimers often change the shape of the DNA in the cell and cause problems during replication ultimately leading to cell death. Both ionizing and non-ionizing radiation are used to control the growth of microorganisms in clinical settings, the food industry, and in laboratories.

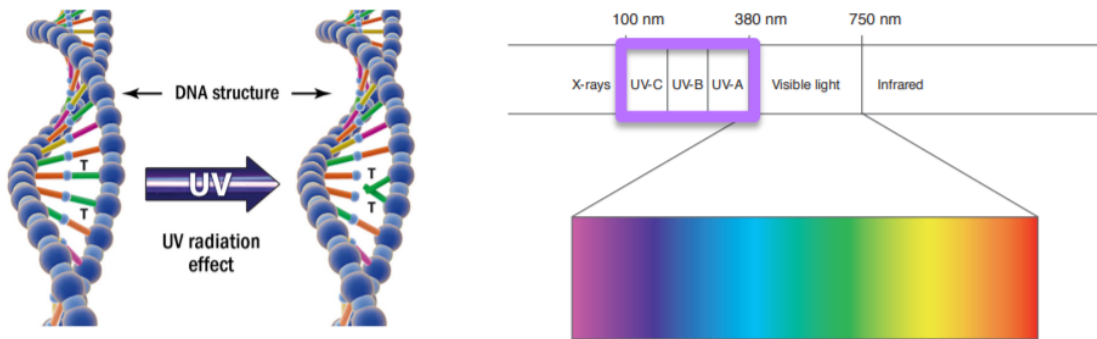

#### WHAT IS THE EFFECT OF UV LIGHT EXPOSURE ON 3 DIFFERENT SPECIES OF BACTERIA?

1. Each table will be given one of the following bacterial species/stages:

- *Staphylococcus aureus*
- *Serratia marcescens*
- *Bacillus cereus* (vegetative)
- *Bacillus cereus* (spores)

2. Working as a table, use a cotton swab to make a lawn on the following 8 plates:

- no UV exposure (control)
- 15 seconds
- 30 seconds
- 1 min
- 3 min
- 5 min
- 10 min
- 10 min with the plate fully covered with a lid

3. Put your plates (with the half lids) under UV light for the appropriate exposure time. Make sure to mark on the bottom of your plate which half of the plate was exposed to UV light and incubate them at 37°C.

#### Note

UV light can burn your skin and eyes. Take proper precautions to protect yourself.

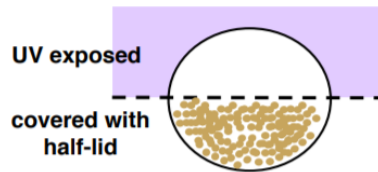

if UV light exposures kills the bacteria you would expect to see a plate that looks like this after incubation

## Steam Demo:

### How does steam sterilization work?

Of the various methods we have developed to sterilize materials, steam is the most effective, common, and economical. The device used most commonly for this purpose is an autoclave, also known as a steam sterilizer. Autoclaves are relatively safe and easy to operate and extremely effective at killing microbial vegetative cells and spores. Similar to home pressure cookers, which create pressure and high temperatures to shorten cooking times, autoclaves use super-heated steam under pressure to kill microbes. Sterilizing temperatures are usually 121-127°C (250-260°F) for at least 15 minutes.

We can test the effectiveness of an autoclave by using commercially available ampules (sealed glass capsules of bacterial spores). Bacterial spores are used because they are the most difficult to kill and therefore the highest measure of antimicrobial killing efficiency.

If the bacteria live after sterilization, they produce acid which turns the indicator yellow. If the bacteria are dead the indicator will remain purple.



## TESTING THE EFFICIENCY OF STEAM STERILIZATION:

4. Make sure you look at the tubes, know what they look like AND what they mean:

- Negative Control = ampule autoclaved → not incubated = no growth = purple color
- Positive Control = ampule not autoclaved → incubated = growth = acid produced = yellow color
- Sterilization success = ampule autoclaved → incubated = no growth = purple color

Vial	Placement of Vial	Results (yellow or purple)	Did the Spores Survive?
A	(-) control = autoclaved but not incubated		
B	(+) control = not autoclaved, incubated at 55°C		
C	Autoclaved then incubated at 55°C		
D	Placed inside multiple containers, autoclaved, then incubated at 55°C		

## Chemical

### How effective are chemical germicides?

Chemical germicides should reduce the number of pathogens on a surface, in a liquid, or on/in living tissues. Germicides designed for use on surfaces are called disinfectants. Germicides designed for use on living tissues are called antiseptics. To test the effectiveness of a chemical against pathogens, glass beads are coated with bacteria, exposed to different concentrations of germicides, and finally transferred to a growth medium. After incubation, the growth rates are determined. The more effective the germicide, the less bacterial growth there will be.

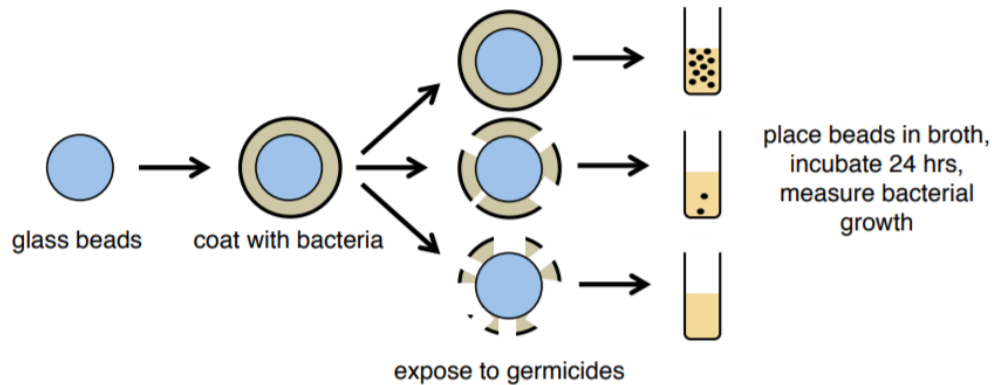

### HOW EFFECTIVE ARE FOUR DIFFERENT COMMON GERMICIDES?

5. Each table will be assigned one of the following disinfectants, which they will then need to dilute to the following concentrations:

- Bleach (1%, 0.1%, and 0.01%)
- Bench-top disinfectant (100%, 50%, 25%)
- Hydrogen peroxide (3%, 0.3%, 0.03%)
- Alcohol (50%, 30%, 10%)

6. One side of the table will use *Escherichia coli* and the other side will use *Staphylococcus epidermidis*.

7. Each side of a table will need 5 empty Petri dishes, 7 TSB broth tubes, and 5-6 beads.

It may be helpful to view the summary figure next page before proceeding.

8. For this experiment you will have four controls, you can ASEPTICALLY prepare the first set now.

- Negative control A = broth, uninoculated → to make sure broth isn't contaminated
- Positive control A = broth + one loopful of bacteria from your culture → to make sure bacterial culture provided is healthy and growing

9. ASEPTICALLY pipette 10 ml of sterile water into SMALL empty, pre-labeled Petri dishes. Then, pipette 10 ml of each of your 3 dilutions into empty Petri dishes. Below is an example of what your dishes would look like if you had been assigned bleach.

Pipette water first. Then, go from your lowest to highest dilution.

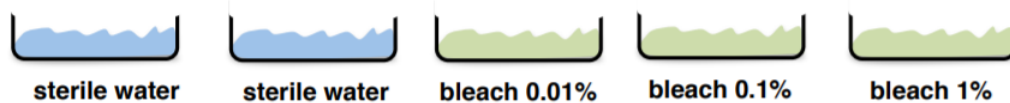

10. With sterile forceps drop 6 beads into your *Escherichia coli* or *Staphylococcus epidermidis* broth tube and wait 1 minute.

11. Using a glass Pasteur pipette, remove the broth and discard into the beaker of disinfectant provided.

12. Pour out the beads and the remaining volume of broth onto filter paper. With sterile forceps separate the beads, place the lid back on and allow to air dry for 10 minutes.
13. Place one bead in each Petri dish of disinfectant and one water Petri dish. Wait 10 minutes.
14. Into the fifth plate, place a sterile and uncoated bead.
15. With sterile forceps remove the beads and place each bead in a broth tube. Mix thoroughly and incubate them at 37°C.

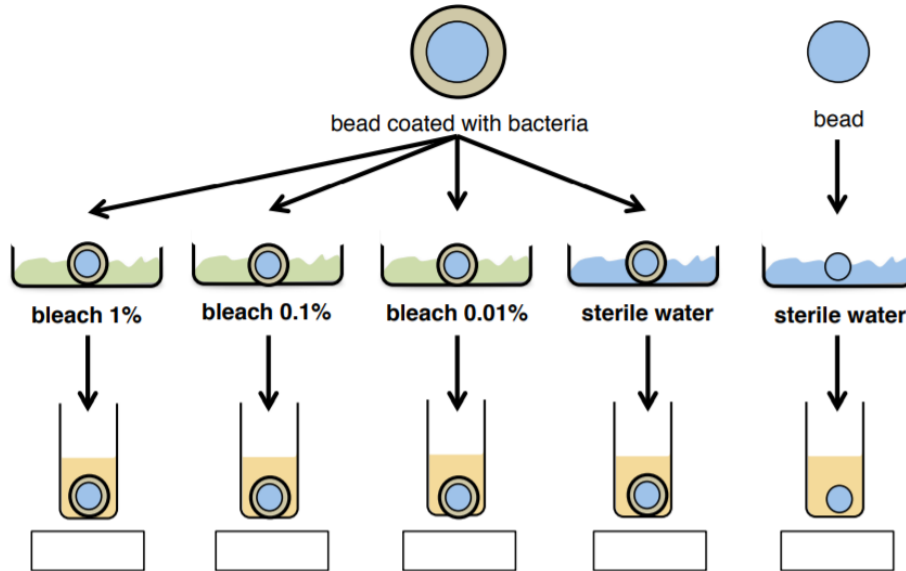

**exercise**

If your bacteria is susceptible to bleach, can you guess what the expected results will be for each condition?

Use the following symbols:

- + = growth
- +/- = little growth
- ng = no growth

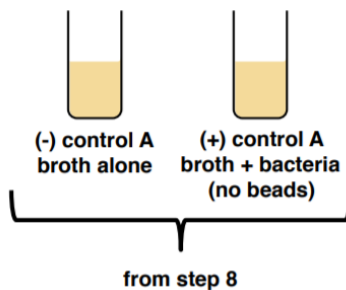

**Results:**

For your UV plates draw your results below:

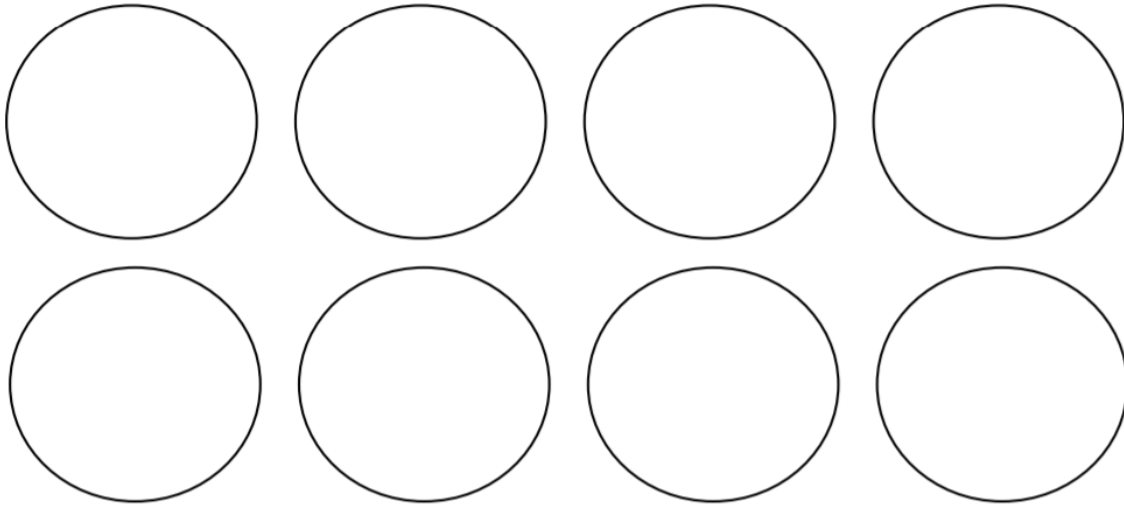

For your broth plates complete the table below using +/- symbols. This is a relative way of measuring growth. You will have to determine for yourself what is high growth and what is low growth but your controls should help.

- +++ = high growth, very turbid
- ++ = average growth, turbid
- + = low growth, slightly turbid
- +/- = almost no growth
- ng = no growth

	Bleach			Bench-top Disinfectant			H <sub>2</sub> O <sub>2</sub>			Alcohol		
	0.01%	0.10%	1%	25%	50%	100%	0.03%	0.30%	3%	10%	30%	50%
<i>E. coli</i>												
<i>S. epi</i>												

This page titled [Lab 7: Sterilization](#) is shared under a [CC BY-SA](#) license and was authored, remixed, and/or curated by [Nazy Pakpour & Sharon Horgan](#).

## Lab 7: Worksheet

---

Name: \_\_\_\_\_

Section: \_\_\_\_\_

Student ID#: \_\_\_\_\_

Work in groups on these problems. You should try to answer the questions without referring to your textbook. If you get stuck, try asking another group for help.

1. Which UV exposure time/condition had the least amount of bacterial colonies? Why? (1)
2. Can UV light destroy bacterial spores? (0.5)
3. How did wrapping the tubes prior to autoclaving them affect the ability of the autoclave machine to sterilize? (0.5)
4. What germicide was the best at killing *E. coli*? *S. epidermidis*? (1)
5. Is there a difference between the germicides that work against *E. coli* vs. *S. epidermidis*? Why? (1)
6. What do the control tubes with the beads control for? Which is the positive and which is the negative control? (1)

---

This page titled [Lab 7: Worksheet](#) is shared under a [CC BY-SA](#) license and was authored, remixed, and/or curated by [Nazzy Pakpour & Sharon Horgan](#).

## Lab 8: Membrane Filtration

### is there poop in your water?

Safe drinking water is a problem for nearly 1 billion people worldwide. Diarrhea caused by drinking contaminated water is still a leading cause of illness and death among infants and children in the developing world. Over 1000 children die every day as a result of diseases that cause diarrhea. More children die from diarrheal illnesses such as cholera, dysentery, and typhoid fever than from HIV/AIDS and malaria combined.

This is primarily caused by fecal contamination of open water. Certain members of the Enterobacteriaceae family such as *Escherichia coli*, *Klebsiella pneumoniae*, and *Enterobacter aerogenes* are relatively abundant in feces and easy to detect. Therefore, these organisms are used as an indicator species when testing water for fecal contamination. These bacteria are gram-negative, facultative anaerobes that are able to ferment lactose to produce large amounts of acid and gas.

Bacteria that possess these qualities are called coliform. Once the presence of coliform bacteria is detected in a water source, further tests are done to determine if more dangerous fecal-borne pathogens are present.



Membrane filtration is a technique for testing water samples. In this procedure, water is drawn through a special porous membrane designed to trap microorganisms larger than 0.45  $\mu\text{m}$ . Afterward, the filter is applied to the surface of Endo agar plates and incubated for 24 hours. **Endo agar** is a selective media that encourages gram-negative bacterial growth and inhibits gram-positive growth. It also contains lactose for fermentation and a dye to indicate pH changes. Coliform colonies typically appear with a gold/metallic sheen.

After incubation, all metallic colonies are counted and are used to calculate the number of coliform colonies/volume filtered using the following formula:

$$\frac{\text{total coliforms}}{\text{volume filtered}}$$

A countable plate has 20-200 coliform colonies.

### Complete the following experiment working as a pair:

1. Label 2 Endo agar plates.
2. Filter 100 mL. of control and sample water that you have been provided through a filter (filter needs to be changed between each sample).
3. Using sterile forceps, place the filter on the filter housing.
4. Clamp the top half of the assembly.
5. Pour the water inside and open the vacuum.
6. Once all the water is passed through close the vacuum, remove the top half of the filter.
7. With sterile forceps, remove the filter and place it in the middle of the Endo agar plate.

This page titled [Lab 8: Membrane Filtration](#) is shared under a [CC BY-SA](#) license and was authored, remixed, and/or curated by [Nazy Pakpour & Sharon Horgan](#).

## Lab 8: Worksheet

---

Name: \_\_\_\_\_

Section: \_\_\_\_\_

Student ID#: \_\_\_\_\_

Work in groups on these problems. You should try to answer the questions without referring to your textbook. If you get stuck, try asking another group for help.

Sample	Number of Colonies	Would You Drink It?

1. Why is Endo Agar used for our membrane filtration experiment and not a TSA plate? (1)
2. What would happen if we used glucose in our Endo agar plates instead of lactose? (1)
3. What does the term coliform mean? (1)
4. How many bacterial colonies does a 'countable' plate have? (1)
5. What are the bacterial species most abundant in feces? (1)

---

This page titled [Lab 8: Worksheet](#) is shared under a [CC BY-SA](#) license and was authored, remixed, and/or curated by [Nazy Pakpour & Sharon Horgan](#).

## Lab 9: Standard Plate Count

### How do we know how many bacteria are in a liquid?

Microbiologists use a technique called the ‘standard plate count’ to estimate the population density of bacteria in a broth by plating a small and dilute portion of the sample and counting the number of bacteria colonies. We use serial dilutions to create decreasing concentrations of the original sample that are then plated so that a plate will be created with a low enough number of bacteria that we can count individual colonies. From that number, we can calculate the original cell density in the broth.

### what do we dilute?

A turbid broth tube contains millions of bacteria. If we transferred directly from that tube, we would get a plate that had a lawn of bacteria. This plate would be uncountable and we could not use it to estimate bacterial cell numbers. Therefore, we need to dilute our original sample before plating.

### Why do we do a dilution series?

Since we don’t know how much bacteria is in our broth sample we don’t know how much we need to dilute it in order to get a ‘countable’ plate (between 30-300 bacteria). Therefore, we do a dilution series to create a number of plates, with a range of dilutions, in the hope of producing a countable plate. The number of colonies we count on a plate gives us the CFU or colony forming units, when we divide the CFU, by the volume we plated we get CFU/volume à CFU/mL. For example, if we counted 32 bacteria on a plate that had received 200 µl of a 10<sup>-6</sup> dilution, we would do the following math:

$$\frac{32 \text{ CFUs}}{0.2 \text{ mL}} = 160 \frac{\text{CFU}}{\text{mL}} \quad (\text{Lab 9.1})$$

We then divide this by how much we diluted the original sample to get the estimated concentration of bacteria in the original tube:

$$\frac{160 \frac{\text{CFU}}{\text{mL}}}{10^{-6}} = 160 * 10^6 \frac{\text{CFU}}{\text{mL}} \quad (\text{Lab 9.2})$$

Putting this in correct scientific notation this would be:

$$1.6 * 10^8 \frac{\text{CFU}}{\text{mL}} \quad (\text{Lab 9.3})$$

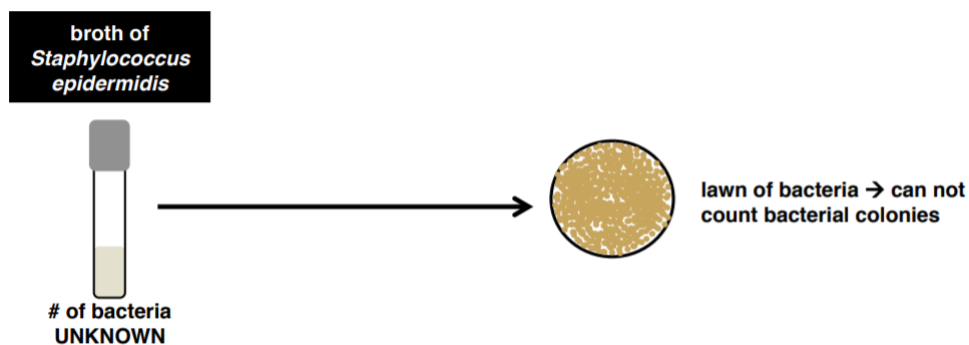

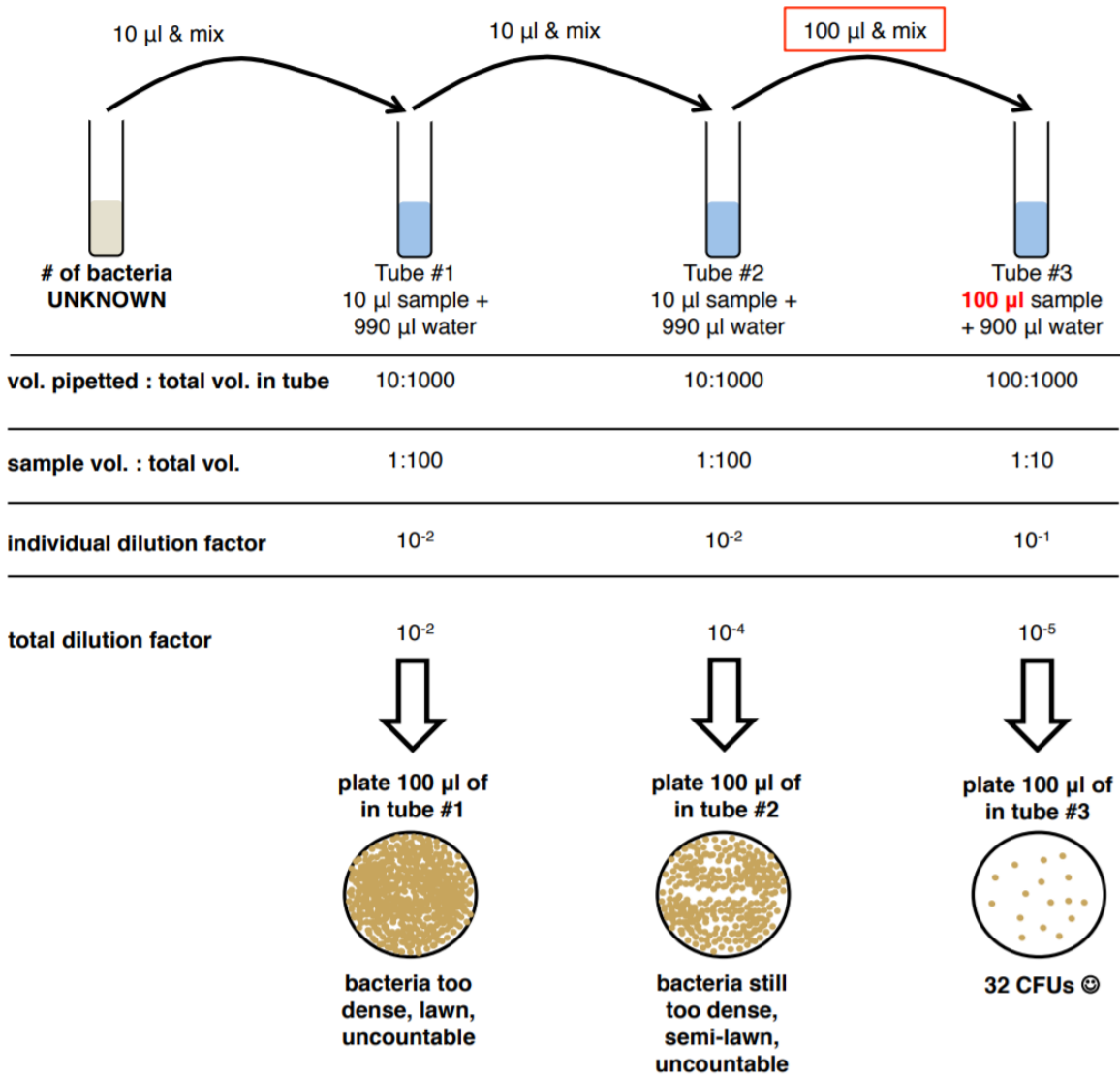

**NOTE**

Calculate the CFU/mL for this experiment, show your work, and have the instructor sign off before proceeding.

**Exercise**

Fill in the chart below before proceeding (you do not need to turn this in).

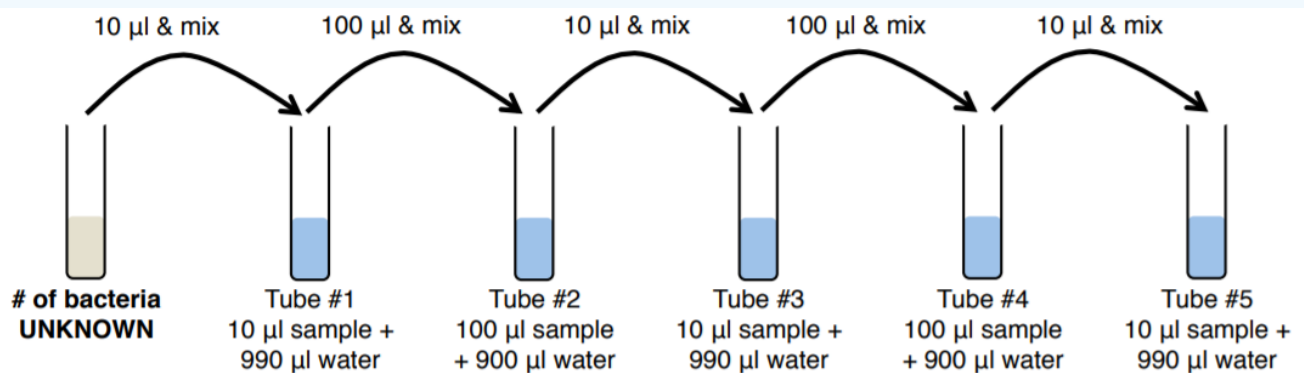

Volume Pipetted: Total Volume (Ratio)					
Sample Volume: Total Volume (Ratio)					
Individual Dilution Factor					
Total Dilution Factor					

### Complete the Following Lab Individually:

1. Obtain 7 microcentrifuge tubes and label them #1-7.
2. Aseptically add 990  $\mu\text{L}$  of sterile water to tubes #1 and #2.
3. Aseptically add 900  $\mu\text{L}$  of sterile water to tubes #3-7.
4. Mix the broth culture, then aseptically add 10  $\mu\text{L}$  to tube #1 and vortex.
5. Aseptically transfer 10  $\mu\text{L}$  from tube #1 to tube #2, close the lid and vortex.
6. Aseptically transfer 100  $\mu\text{L}$  from tube #2 to tube #3, close the lid and vortex.
7. Aseptically transfer 100  $\mu\text{L}$  from tube #3 to tube #4, close the lid and vortex.
8. Aseptically transfer 100  $\mu\text{L}$  from tube #4 to tube #5, close the lid and vortex.
9. Aseptically transfer 100  $\mu\text{L}$  from tube #5 to tube #6, close the lid and vortex.
10. Aseptically transfer 100  $\mu\text{L}$  from tube #6 to tube #7, close the lid and vortex.

**CONGRATULATIONS YOU HAVE NOW COMPLETED YOUR DILUTION SERIES!**

# of bacteria  
UNKNOWN

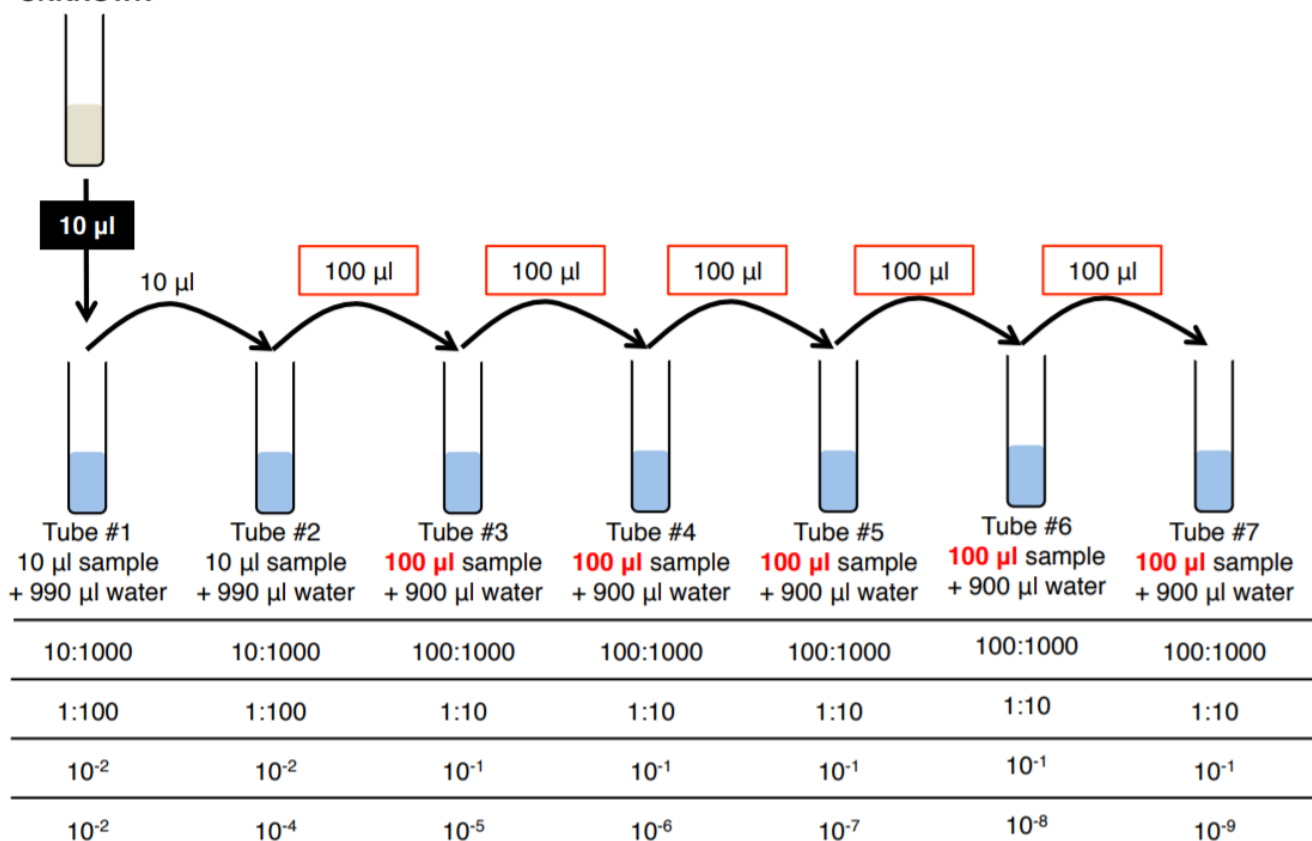

11. Obtain 4 TSA plates and label them.
12. Using the magic of fire to bend a glass Pasteur pipette into a spreader. Place it in your beaker of alcohol.
13. Flame your glass spreader, wait for ALL the alcohol to evaporate and repeat this 3 times.
14. Aseptically pipette 100 µL of tube #4 onto the center of a TSA plate while making sure the tip does not touch the agar.
15. Place the sterilized spreader onto the center of your plate (DO NOT PRESS DOWN).
16. Turn the plate at least 5 times as you move the glass spreader to distribute the bacteria over the plate. At this point, the liquid has been absorbed by the plate.
17. Place the glass spreader back into your beaker of alcohol.
18. Repeat this procedure for tubes #5-7, incubate at 37°C.

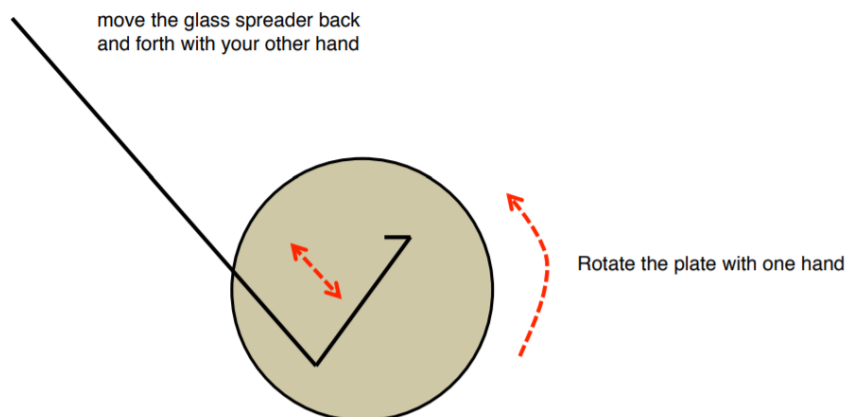

---

This page titled [Lab 9: Standard Plate Count](#) is shared under a [CC BY-SA](#) license and was authored, remixed, and/or curated by [Nazzy Pakpour & Sharon Horgan](#).

## Lab 9: Worksheet

---

Name: \_\_\_\_\_

Section: \_\_\_\_\_

Student ID#: \_\_\_\_\_

Work in groups on these problems. You should try to answer the questions without referring to your textbook. If you get stuck, try asking another group for help.

1. For your dilution plates draw your results below. (1)

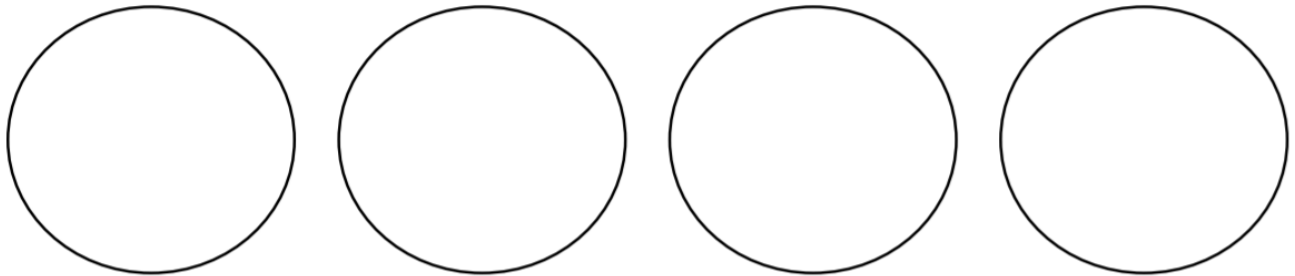

2. Calculate the original CFUs in your original broth tube, if you are within 500 CFUs of what Dr. Pakpour calculated you can earn 5 extra credit points! (1)

3. A plate has 72 colonies with a total dilution factor of  $10^{-7}$ , 100  $\mu\text{L}$  was pipetted onto the plate, what was the original CFU concentration of that sample? (1)

4. How do you know if you have a 'countable' plate when doing a dilution series? (1)

5. Two plates received 100  $\mu\text{L}$  of the same dilution tube. The first has 293 colonies and the second has 158 colonies. Suggest a reasonable reason why this happened. (1)

---

This page titled [Lab 9: Worksheet](#) is shared under a [CC BY-SA](#) license and was authored, remixed, and/or curated by [Nazy Pakpour & Sharon Horgan](#).

## Lab 10: Plaque Assay and Biochemical Tests (Day 1)

### How do we count viruses?

Unlike bacteria, many of which can be grown on an artificial nutrient medium, viruses require a living host cell for replication. Infected host cells (eukaryotic or prokaryotic) can be cultured and grown, and then the growth medium can be harvested as a source of virus. In this lab, we will be quantifying bacteriophages (viruses that attack bacteria) using a plaque assay. This means that we must grow both bacteria and virus.

As the virus replicates and grows, it will lyse bacteria resulting in an area of clearing that can be observed on a bacterial lawn. These clearings are called plaques. A plaque assay, therefore, is a method by which the number of plaques observed can be used to estimate the amount of virus present in the original culture. The technique required to do so is called the pour-plate technique because you will mix the virus with the bacteria with melted agar and then pour the mixture onto a plate.

The unit of viral titer (concentration) is plaque-forming units per milliliter (pfu/ml).

As we do not know the starting concentration of virus, we will need to do a serial dilution (similar to the standard plate count). After incubation, the number of plaques formed will be used to calculate the original viral (phage) titer.

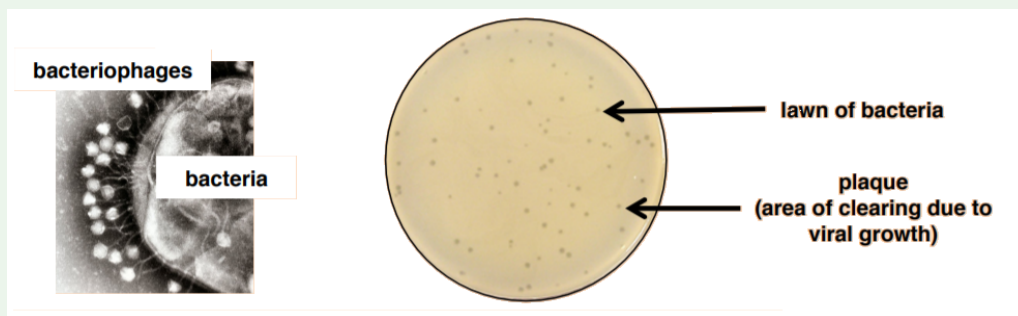

### Plaque Assay:

#### Complete the Following Lab with Your Partner:

1. Obtain 14 microcentrifuge tubes and label either #1-7 or E. coli #1-7.
2. Obtain 7 nutrient agar plates. Label them A-G and place them in the 37°C incubator to warm up until needed.
3. Aseptically add 990  $\mu\text{L}$  of sterile saline to tubes #1.
4. Aseptically add 900  $\mu\text{L}$  of sterile saline to tubes #2-7.
5. Finger vortex the E. coli broth. Then, aseptically add 300  $\mu\text{L}$  to all seven E. coli microcentrifuge tubes.
6. Vortex the T4 bacteriophage suspension and then aseptically transfer 10  $\mu\text{L}$  to tube #1. Close the lid and vortex. This is your 10-2 dilution.

#### Note

Enterobacteria phage T4 is a bacteriophage that infects *Escherichia coli* bacteria.

7. Aseptically transfer 100  $\mu\text{L}$  from tube #1 to tube #2, close the lid and vortex. This is your 10-3 dilution.
8. Aseptically transfer 100  $\mu\text{L}$  from tube #2 to tube #3, close the lid and vortex. This is your 10-4 dilution.
9. Aseptically transfer 100  $\mu\text{L}$  from tube #3 to tube #4, close the lid and vortex. This is your 10-5 dilution.
10. Aseptically transfer 100  $\mu\text{L}$  from tube #4 to tube #5, close the lid and vortex. This is your 10-6 dilution.
11. Aseptically transfer 100  $\mu\text{L}$  from tube #5 to tube #6, close the lid and vortex. This is your 10-7 dilution.
12. Aseptically transfer 100  $\mu\text{L}$  from tube #6 to tube #7, close the lid and vortex. This is your 10-8 dilution.
13. Aseptically transfer 100  $\mu\text{L}$  of SALINE into tube E. coli #1, close the lid and vortex. This will become your negative control.

14. Aseptically transfer 100  $\mu$ L of dilution tube #2 to E. coli #2, close the lid and vortex.
15. Aseptically transfer 100  $\mu$ L of dilution tube #3 to E. coli #3, close the lid and vortex.
16. Aseptically transfer 100  $\mu$ L of dilution tube #4 to E. coli #4, close the lid and vortex.
17. Aseptically transfer 100  $\mu$ L of dilution tube #5 to E. coli #5, close the lid and vortex.
18. Aseptically transfer 100  $\mu$ L of dilution tube #6 to E. coli #6, close the lid and vortex.
19. Aseptically transfer 100  $\mu$ L of dilution tube #7 to E. coli #7, close the lid and vortex.
20. Let all seven tubes stand for 15 minutes. We are allowing time for the virus to infect the bacteria.
21. Remove one soft agar tube (containing 2.5 ml of agar) from the hot water bath and add the entire contents of E. coli #1 to it. Using a sterile plastic transfer pipet, mix the contents by pipetting up and down twice. (DO NOT USE YOUR MICROPIPETTER FOR THIS OR YOU WILL LOSE POINTS!!!)
22. Immediately pour the mixture onto plate A. Then, gently tilt the plate back and forth until the soft agar mixture is spread evenly across the solid medium.

#### Note

Remember that you need to take the soft agar plates and nutrient agar plates out one at a time. Otherwise, the agar will solidify before you have a chance to pour.

23. Allow the agar to solidify completely with the lid on at your table (15-20 minutes). Then, invert and place in the 37°C incubator to grow overnight.

## Biochemical Test (Day 1):

### How do we identify the bacteria?

Each bacteria species has a distinctive metabolism that produces unique metabolites. We can detect these features through biochemical assays. Often these tests contain both selective and differential factors.

### selective agent vs differential agent

Selective agent allows only specific bacteria to grow (readout is growth/no growth). Differential agent allows different bacteria to grow in different ways on the same media (e.g. readout is color change; both bacteria grew but in different colors).

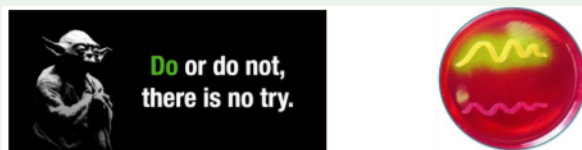

### What is an exoenzyme?

An exoenzyme, or extracellular enzyme, is an enzyme that is secreted by a cell into the environment and functions outside of that cell. Exoenzymes are produced by both prokaryotic and eukaryotic cells. Most often these enzymes are involved in the breakdown of larger macromolecules. The breakdown of these larger macromolecules is critical for allowing their smaller components to pass through the cell membrane and enter into the cell. Bacteria and fungi also produce exoenzymes to digest nutrients in their environment, and these organisms can be used to conduct laboratory assays to identify the presence and function of such exoenzymes. Some pathogenic species also use exoenzymes as virulence factors to assist in their spread. In this lab, you will test for three exoenzymes: amylase, lipase, and caseinase.

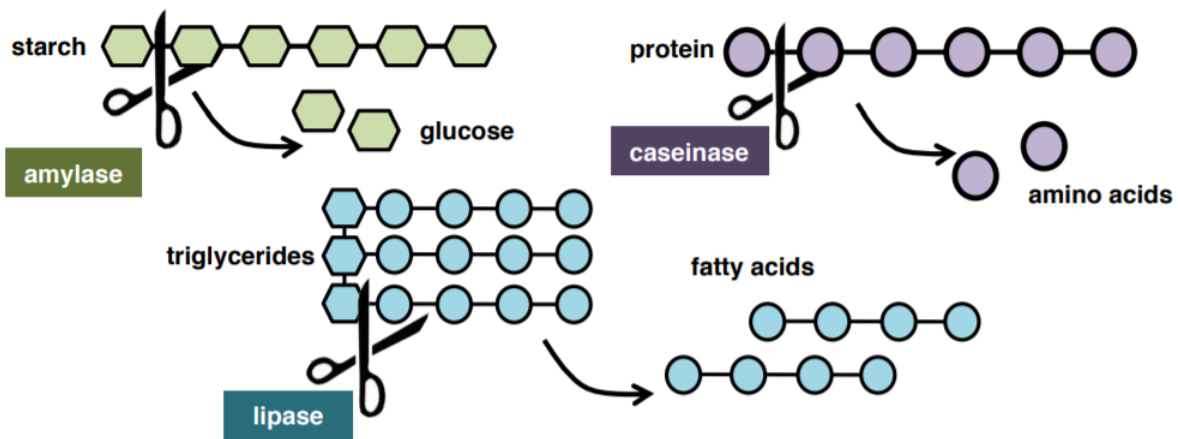

1. WORKING AS A PAIR, collect your three exoenzyme plates (starch, lipase, casein) and your assigned bacteria from the instructor.
2. Divide each plate in half. Using aseptic technique, on one half of the plate streak a straight line (NOT SFIC, NOT A LAWN!) your assigned bacteria with a loop.
3. On the other half of the plate streak the positive control.
4. Incubate all plates at 37°C.

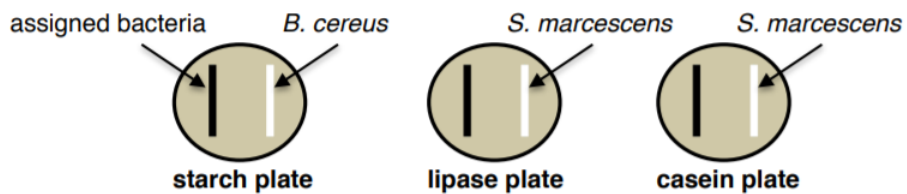

**How do you like your sugar?**

Carbohydrates (sugars) are a large and diverse family of organic molecules that are used by cells for energy. Before bacteria can utilize these sugars, they must first bring them into the cell via transmembrane sugar transporters. If they lack the correct transporter, they can not metabolize the sugar and will use the peptone instead.

Phenol Red Broth is a general-purpose differential test medium typically used to differentiate gram-negative enteric (gut) bacteria. It contains peptone, phenol red (a pH indicator), a Durham tube, and one carbohydrate (sugar). If the organism is able to utilize the carbohydrate, an acid by-product is created, which turns the media yellow. If the organism is unable to utilize the carbohydrate but does use the peptone, the by-product is ammonia, which raises the pH of the media and turns it fuchsia.

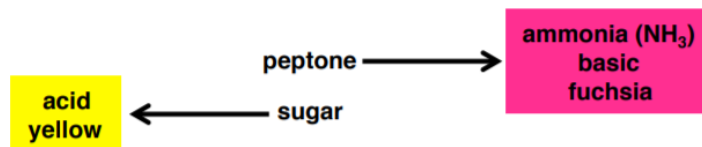

5. Collect your three phenol red broth tubes (glucose, sucrose, lactose) and label them.
6. Aseptically inoculate your tubes with a loopful of your assigned bacteria. All tubes will be placed in the rack at the end of the table and placed in 37°C incubator at the end of class.

**Nitrate broth**

It is used to determine whether bacteria contain the enzyme nitrate reductase, which reduces nitrate to nitrite (NO<sub>3</sub> → NO<sub>2</sub>)

7. Collect four nitrate tubes and label them.

8. Aseptically inoculate each of your tubes with a loopful of the following bacteria:

- Assigned bacteria
- *Alcaligenes faecalis*
- *Escherichia coli*
- *Pseudomonas aeruginosa*

### gelatin

Gelatin is a protein derived from collagen, a connective tissue of animals. When chilled on ice, gelatin forms cross-links to itself to create a semi-solid state (jello!). Gelatin provides a rich source of amino acids and peptides for bacteria, but is too large to be transported inside the cell directly. Therefore, it must first be broken down by exoenzyme proteins such as gelatinase. When bacteria that have this enzyme are inoculated into a nutrient gelatin medium, the gelatin never forms a semi-solid state, even after chilling.

9. Collect one gel tube and label it.

10. Aseptically inoculate your tube by stabbing it with a loopful of your assigned bacteria (yes I really mean a loop). Make sure your cap is loose and place it in the rack at the end of the table.

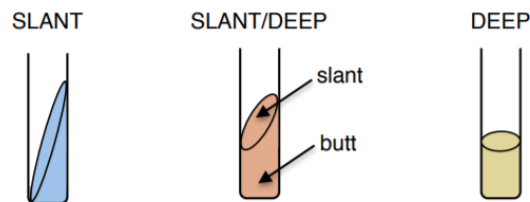

### Triple sugar iron (TSI) slant/deep

It tests the ability of bacteria to ferment sugars and to produce  $H_2S$ , often used to identify *Salmonella* and *Shigella*. The medium contains sugars (lactose, sucrose, and glucose) and thiosulfate. Slant/deep allows for aerobic and anaerobic growth conditions.

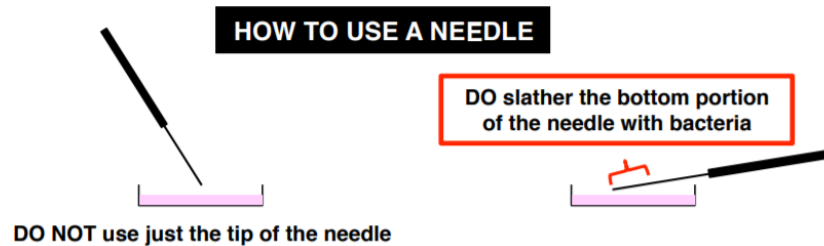

11. Inoculate your TSI slant/deep with your assigned bacteria using a needle by stabbing fully into the butt ONCE and only ONCE.

12. Then, streak across the slant WITHOUT re-dipping your needle in your plate. KEEP CAPS LOOSE and place it on the rack at the end of the table to be incubated at 37°C

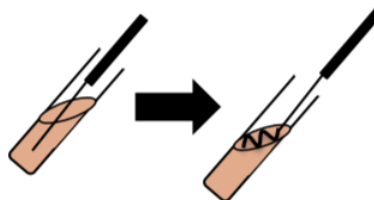

### Decarboxylase broths

Used for the differentiation of gram-negative enteric bacilli based on the production of arginine dihydrolase, lysine decarboxylase, or ornithine decarboxylase.

13. Aseptically inoculate your decarboxylate broths (including the control) with a loopful of your assigned bacterial culture.
14. Add 10-12 drops of mineral oil to top of each tube.
15. Tighten caps closed (but not He-Man closed) and place in the racks at the end of the table to be incubated at 37°C.



### Urea broth

Urease broth is a differential medium that tests the ability of an organism to hydrolyze urea into ammonia and carbon dioxide using the enzyme urease.

16. Inoculate urea broth with loopful of your assigned bacterial culture.
17. Place in the racks at the the end of the table to be incubated at 37°C.

### SIM medium

Used in the differentiation of gram-negative enteric bacilli on the basis of sulfide production, indole formation, and motility.

### Methyl Red & Voges-Proskauer (MR-VP) broth

The MR test detects bacteria that use the mixed acid fermentation pathway (red=positive); the VP test detects bacteria that use the butylene glycol pathway (red=positive).

### Citrate slant

Often used for the detection of gram-negative enteric bacilli based on the ability of an organism to use citrate as the sole source of carbon and energy.

Together these tests make up a very common microbiology lab procedure called the IMViC. "I" is for indole test; "M" is for methyl red test; "V" is for Voges-Proskauer test, and "C" is for citrate test. IMViC tests are used in microbiology labs to identify gram-negative, aerobic, or facultative anaerobic rods which produce gas from lactose. The presence of these bacteria indicates fecal contamination.

18. Inoculate SIM medium with your assigned bacteria using a needle by stabbing ONCE.
19. Place on the rack at the end of the table to be incubated at 37°C.



20. Aseptically inoculate one MR-VP broth tubes with a loopful of your assigned bacteria.
21. Place on the rack at the end of the table to be incubated at 37°C.



22. Aseptically streak your citrate slant with a SMALL loopful of your assigned bacteria.
23. Place on the rack at the end of the table to be incubated at 37°C.



### MacConkey Agar (MAC)

Often used to differentiate members of the Enterobacteriaceae on the basis on their ability to ferment lactose. Any bacteria capable of fermenting lactose forms pink colonies.

24. Streak your assigned bacteria, *Escherichia coli* and *Shigella flexneri*, as shown on MAC and TSA plates.

25. Incubate all plates at 37°C.

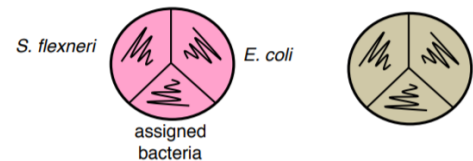

This page titled [Lab 10: Plaque Assay and Biochemical Tests \(Day 1\)](#) is shared under a [CC BY-SA](#) license and was authored, remixed, and/or curated by [Nazzy Pakpour & Sharon Horgan](#).

## Lab 10: Worksheet

Name: \_\_\_\_\_

Section: \_\_\_\_\_

Student ID#: \_\_\_\_\_

Work in groups on these problems. You should try to answer the questions without referring to your textbook. If you get stuck, try asking another group for help.

### Plague Assay

Record your results below. A countable plate has between 30-300 plaques. If there are more than 300 plaques record TMTC (too many to count), if there are fewer than 30 plaques record TFTC (too few to count) (1).

	A	B	C	D	E	F	G
Plaques Counted							
Sample Volume	2.5 mL.	2.5 mL.	2.5 mL.	2.5 mL.	2.5 mL.	2.5 mL.	2.5 mL.
$\frac{PFU}{mL}$							
$\frac{PFU}{mL \text{ of starting tube}}$							

1. Why is it important in this assay to make sure that there are enough bacteria present to produce a lawn? (1)
2. What would happen if you had not waited the 15 minutes that the protocol requires? (1)
3. Why was the water bath set to 50°C? (1)
4. What is the difference between a CFU and a PFU? (1)

This page titled [Lab 10: Worksheet](#) is shared under a [CC BY-SA](#) license and was authored, remixed, and/or curated by [Nazzy Pakpour & Sharon Horgan](#).

## Lab 11: Biochemical Tests (Day 2)

### BIOCHEMICAL TESTS (DAY 2):

#### catalase test

Tests for the presence of catalase enzyme that converts hydrogen peroxide (H<sub>2</sub>O<sub>2</sub>) into water and oxygen gas

#### oxidase test

Used to determine if a bacterium has enzyme cytochrome oxidase. The reagent is colorless if negative and turns blue/purple when oxidized.

#### CATALASE TEST:

1. On a glass slide, add 1-2 drops of H<sub>2</sub>O<sub>2</sub>.
2. Add loopful of a single species of bacteria from your plate to the slide; bubbles = positive result
3. Repeat for all four bacteria AND YOUR ASSIGNED BACTERIA from your TSA plate

#### OXIDASE TEST:

4. Swipe bacteria from your assigned PLATE onto a cotton swab.
5. Dispense 1-2 drops of the oxidase reagent onto the swab and record result.
6. Repeat for all four bacteria AND YOUR ASSIGNED BACTERIA from your TSA plate.

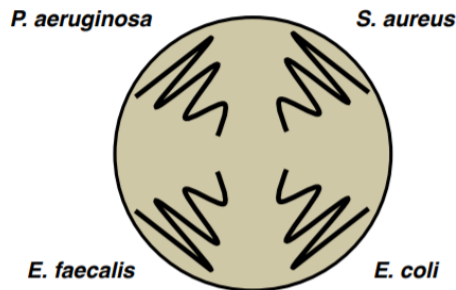

Bacteria	Catalase +/-	Oxidase +/-
	+	+
	+	-
	+	-
	-	-

#### NITRATE BROTH:

Complete the following for each tube of the four tubes of nitrate broth. Observe the inverted Durham tube. If bubbles are present, then the following reaction has occurred and your bacteria is positive for nitrite and nitrate reductase:

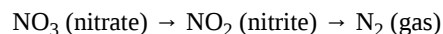

1. If gas is NOT present, then add 3 drops of sulfanilic acid (reagent A) and 3 drops of naphthylamine (reagent B) to your tube. Mix gently by tapping the bottom of the tube and wait 2-3 minutes. If your tube turns red, then bacteria is positive for nitrate reductase and the following reaction has occurred:

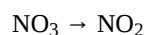

2. If no red color is observed, add a TINY amount of powdered zinc using a toothpick and mix gently by tapping the bottom of the tube.

**Note**

If your sample turns red after step 2, DO NOT do step 3

3. Wait 15 minutes. If your tube turns red, then NO<sub>3</sub> is still present and bacteria are nitrate reductase negative.



**Note**

Hint for lab practical – if I give you a red tube, how can you tell if it is nitrate positive or negative?

	NO <sub>3</sub> present in the tube?	NO <sub>2</sub> present in the tube?	N <sub>2</sub> gas present in the tube?
Assigned bacteria			
<i>Alcaligenes faecalis</i>			
<i>Escherichia coli</i>			
<i>Pseudomonas aeruginosa</i>			
	NO <sub>3</sub> is detected by?	NO <sub>2</sub> is detected by?	N <sub>2</sub> is detected by?

**STARCH PLATES:**

4. Add enough iodine reagent to flood your plate. WAIT 5 MINUTES. The presence of clear halos surrounding colonies is positive for their ability to digest the starch and indicates the presence of alpha-amylase.

**GELATINASE TEST:**

5. Place your gelatin tube in the ice bucket provided by the instructor for 10 minutes. Then, hold your tube sideways to determine if it is solid (negative result) or liquid (positive result). RECORD RESULTS FOR:

- CASEIN plate
- TRIBUTYRIN plate
- Phenol Red Broths

**TSI SLANTS:**

6. Record your results for your assigned bacteria using the table below.

RESULTS (slant/butt)	SYMBOL	INTERPRETATION
Red/yellow	K/A	Glucose fermentation only; Peptone catabolized.
Yellow/yellow	A/A	Glucose and lactose and/or sucrose fermentation
Red/red	K/K	No fermentation; Peptone catabolized.
Red/no color change	K/NC	No fermentation; Peptone used aerobically
Yellow/yellow with bubbles	A/A,G	Glucose and lactose and/or sucrose fermentation; Gas produced.
Red/yellow with bubbles	K/A,G	Glucose fermentation only; Gas produced.
Red/yellow with bubbles and black precipitate	K/A,G,H <sub>2</sub> S	Glucose fermentation only; Gas produced; H <sub>2</sub> S produced.
Red/yellow with black precipitate	K/A,H <sub>2</sub> S	Glucose fermentation only; H <sub>2</sub> S produced.
Yellow/yellow with black precipitate	A/A, H <sub>2</sub> S	Glucose and lactose and/or sucrose fermentation; H <sub>2</sub> S produced.

No change/no change	NC/NC	No fermentation
A=acid production; G=gas production, K=alkaline reaction; H <sub>2</sub> S=sulfur reduction		

**SIM MEDIA:**

7. Add 5 drops of Kovacs reagent to the tube to detect indole production.

Sulfur	-	+	+	-
Indole	+	-	-	-
Motility	-	+	-	-

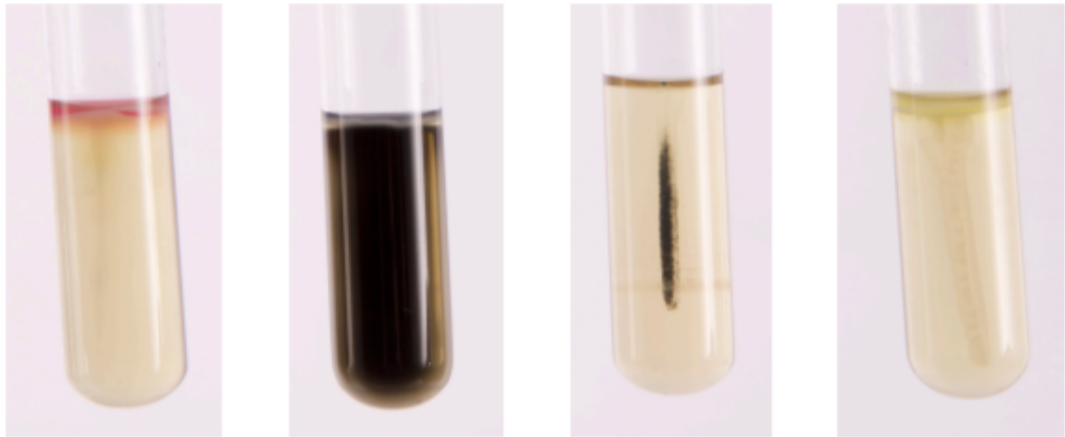

**MR-VP:**

- Using a glass Pasteur pipet, take 1 ml out of your MR-VP broth tube and place it into a new tube
- Add 5 drops MR methyl red reagent to the new tube, record results (positive result = red)
- Using a glass pipet take 1 ml out of MR-VP broth tube and place it into a new tube
- Add 6 drops VP-A and 3 drops VP-B, record results (positive result = red)

RECORD RESULTS FOR:

- Decarboxylate tubes
- Urea broth
- MAC plate

**INDEX:**

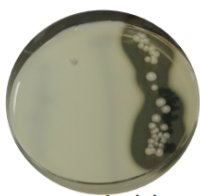

casein (+)

**CASEIN (MILK) PLATE:**

Casein is a large globular protein that gives milk its white and opaque color. It is too large to be transported across the cell membrane. Bacteria that have the exoenzyme 'casease' are able to hydrolyze casein by secreting this enzyme into the environment around them. Clear halos surrounding colonies are indicative of their ability to digest the casein and results in a zone of clearance around plated growth. (+) = halo (-) = no halo

SELECTIVE AGENT: none

DIFFERENTIAL AGENT: casein

INDICATOR: none

**CATALASE TEST:**

Catalases are enzymes that convert hydrogen peroxide (H<sub>2</sub>O<sub>2</sub>) into water and oxygen gas. When a drop of peroxide is placed on catalase-producing bacteria, bubbles appear when the oxygen gas is formed. This is a test for aerobic (able to use oxygen) catalase-

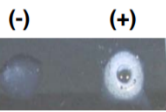

positive bacteria such as *Staphylococcus* and *Micrococcus*.

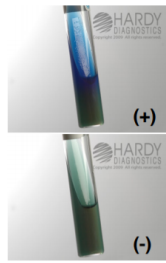

### CITRATE TEST:

Used for the detection of gram-negative enteric bacilli based on the ability of an organism to use citrate as the sole source of carbon and energy. Organisms capable of utilizing ammonium dihydrogen phosphate and citrate will grow unrestricted on this medium. Bromothymol blue acts as a pH indicator, causing the medium to change from green (neutral) to blue (alkaline) with increasing pH. Citrate utilization produces an alkaline carbonate, resulting in a deep blue color change within the agar. The medium will remain green if organisms do not grow or are not able to metabolize sodium citrate.

SELECTIVE AGENT: none

DIFFERENTIAL AGENT: ammonium dihydrogen phosphate and sodium citrate

INDICATOR: bromothymol blue

### DECARBOXYLATE BROTHS:

For the differentiation of gram-negative enteric bacilli based on their ability to break down specific amino acids. The production of the enzymes that break down amino acids (decarboxylase & dihydrolase enzymes) is induced in an acidic environment.

CONTROL: glucose fermented → acid → yellow

ARGININE, LYSINE or ORNITHINE: amino acid degraded → basic → purple

Microorganisms possessing the specific decarboxylase and dihydrolase enzymes for the amino acid (arginine, lysine or ornithine) degrade the amino acid to yield various amine by-products which create an alkaline environment that turns the indicator purplish. If the organism does not produce the appropriate enzyme, then the medium will remain yellow.

DIFFERENTIAL AGENT: Arginine, lysine or ornithine amino acids

INDICATOR: bromocresol purple and cresol red



### GELATIN HYDROLYSIS TEST:

Nutrient gelatin is a differential medium that tests the ability of an organism to produce an exoenzyme, called gelatinase, that hydrolyzes gelatin. When gelatin is broken down, it can no longer solidify. If an organism can break down gelatin, the areas where the organism has grown will remain liquid even if the gelatin is chilled.

#### MR

(-) (+)

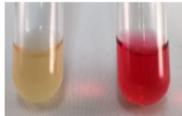

### Methyl Red and Voges-Proskauer (MR-VP):

A medium that contains protein, glucose, and phosphate buffer. Some bacteria produce an acid while other bacteria further metabolize the acid to pH stable end products (Glucose → Acid → Stable End Product). The MR test is used to detect organisms capable of performing mixed acid fermentation where:

- Red=positive
- Orange=inconclusive
- Yellow=negative

#### VP

(-) (+)

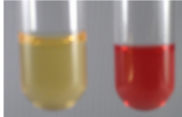

The VP Test is designed for organisms who are able to ferment glucose to acids which are then converted to acetoin and 2,3 butanediol. The addition of VP reagents oxidizes acetoin to diacetyl and reacts with guanidine nuclei from the peptones to produce a red color. Remember:

- Red=positive results
- No color change or copper color=negative

### MANNITOL SALT AGAR PLATE (MSA):

Selective for gram-positive bacteria (e.g. *Staphylococcus* and *Micrococcus*). Mannitol fermentation by pathogenic staphylococci, such as *S. aureus*, is indicated by the media changing to yellow.

SELECTIVE AGENT: NaCl (salt)

DIFFERENTIAL AGENT: mannitol sugar fermentation

INDICATOR: Phenol red

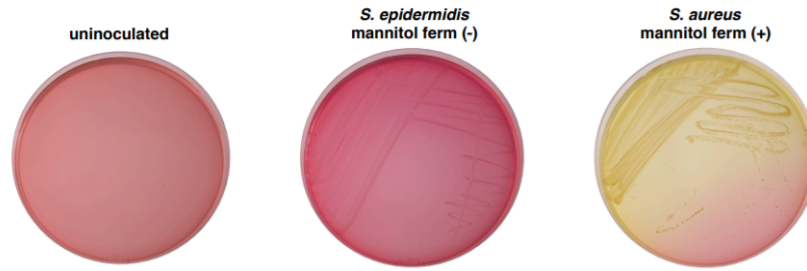

### NITRATE (NO<sub>3</sub>) BROTH:

Determines whether the microbe produces the enzymes nitrate reductase and nitrite reductase. The two enzymes catalyze two reactions involved in converting starting compound nitrate into end product nitrogen gas.

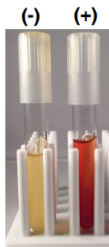
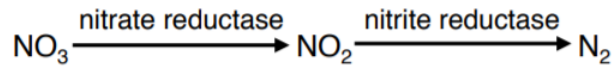

After incubating the nitrate broth, sulfanilic acid (reagent A or 1) and  $\alpha$ -naphthylamine (reagent B or 2) are added. If a red-colored compound forms then nitrate reduction has occurred ( $\text{NO}_3 \rightarrow \text{NO}_2$ ).

An inverted Durham tube tests for the presence of nitrogen gas ( $\text{N}_2$ ).

If neither a red color or gas is observed, then, confirmation is necessary that nitrate ( $\text{NO}_3$ ) remains in the broth. A SMALL addition of zinc dust will convert the nitrate to nitrite and form a red color. This test reaction is considered negative for nitrate reduction.

- Nitrate reductase (+) = red after reagent A & B added
- Nitrite and nitrate reductase (+) = bubbles in durham tube
- Nitrate & nitrite reductase (-) = red after the addition of zinc

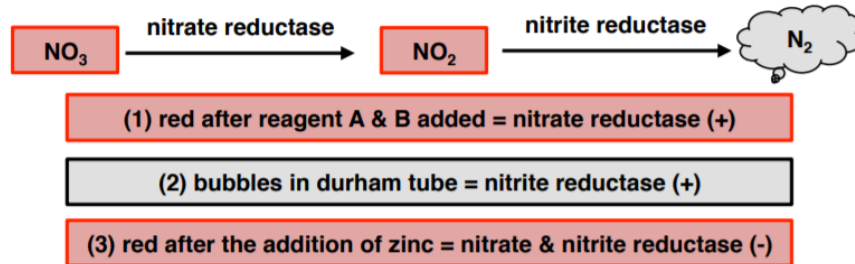

### OXIDASE TEST:

Used to determine if a bacterium has enzyme cytochrome oxidase. The final stage of bacterial respiration involves a series of membrane-embedded components collectively known as the electron transport chain. The final step in the chain may involve the use of the enzyme cytochrome oxidase, which catalyzes the oxidation of cytochrome c while reducing oxygen to form water. The reagent is usually N,N,N',N'-tetramethyl-p-phenylenediamine (TMPD) or N,N-dimethyl-p-phenylenediamine (DMPD), which is also a redox indicator. The reagent is colorless if negative, the color turns blue/purple when oxidized.



### PHENOL RED BROTH:

A general-purpose differential test medium typically used to differentiate gram-negative enteric bacteria. It contains peptone, phenol red (a pH indicator), one carbohydrate (i.e glucose or lactose), and a Durham tube to test for the ability to convert the end product of glycolysis, pyruvic acid, into CO<sub>2</sub> gas.

DIFFERENTIAL AGENT: carbohydrate, Durham tube

INDICATOR: phenol red (-) (+)

### SIM MEDIUM:

For the differentiation of gram-negative enteric bacilli on the basis of sulfide production, indole formation, and motility. H<sub>2</sub>S production is detected when ferrous sulfide, a black precipitate, is produced as a result of ferrous ammonium sulfate reacting with H<sub>2</sub>S gas. Casein peptone is rich in tryptophan, bacteria that possess the enzyme tryptophanase degrade tryptophan to indole. Indole is detected upon the addition of Kovacs Reagent producing a red band at the top of the medium. The semi-solid agar allows for the detection of bacterial motility. Motile organisms extend from the stab line and produce turbidity or cloudiness throughout the medium. Non-motile organisms grow only along the stab line and leave the surrounding medium clear.

Sulfur	-	+	+	-
Indole	+	-	-	-
Motility	-	+	-	-

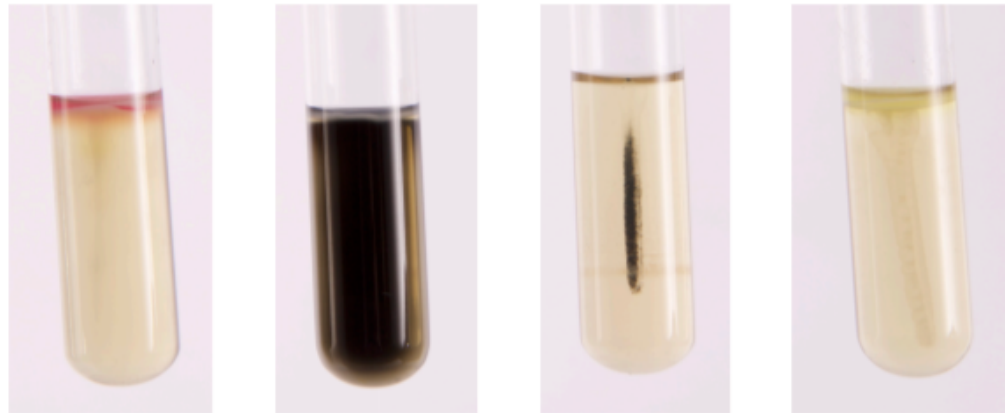

### STARCH AGAR:

Starch is too large to pass through the plasma membrane and must be split into individual glucose molecules. Bacteria that have the exoenzyme amylase are able to hydrolyze starch by secreting these enzymes into the environment around them. After bacteria are allowed to grow, iodine is added to detect the presence of starch. Iodine complexes with starch to form a blue-black color in the culture medium. Clear halos surrounding colonies is indicative of their ability to digest the starch and results in a zone of clearance around plated growth. (+) = halo (-) = no halo

SELECTIVE AGENTS: none

DIFFERENTIAL AGENT: starch

INDICATOR: iodine



### TRIBUTYRIN AGAR:

Tributylin oil is a type of lipid called a triglyceride. It is too large to be transported across the cell membrane. Bacteria that have the exoenzyme lipase are able to hydrolyze tributyrin oil and break it down. Tributyrin oil forms an opaque suspension in the agar. When an organism produces lipase and breaks down the tributyrin, a clear halo surrounds the areas where the lipase-producing organism has grown. (+) = halo (-) = no halo

SELECTIVE AGENTS: none

DIFFERENTIAL AGENT: tributyrin oil

INDICATOR: none

#### TRIPLE SUGAR IRON (TSI) SLANT/DEEP:

Tests the ability of bacteria to ferment sugars and to reduce sulfur to  $H_2S$ , often used to identify *Salmonella* and *Shigella*. Medium contains sugars (lactose, sucrose, and glucose) and thiosulfate. Slant/deep allows for aerobic and anaerobic growth conditions. An alkaline/acid (red slant/yellow butt) reaction is indicative of glucose fermentation only. An acid/acid (yellow slant/yellow butt) reaction indicates the fermentation of glucose, lactose and/or sucrose. The absence of carbohydrate fermentation results in an alkaline/alkaline (red slant, red butt) reaction. If an organism can reduce sulfur, the hydrogen sulfide ( $H_2S$ ) gas which is produced will react with the ferrous ammonium sulfate ( $(NH_4)_2Fe(SO_4)_2 \cdot 6H_2O$ ) to form iron sulfide ( $FeS$ ), which appears as a black precipitate. If  $CO_2$  gas is produced, then the agar will be lifted or cracked as a result.

(A) Uninoculated

(B) K/K

(C) A/A+gas

(D) A/A+  $H_2S$

#### Note

In (D), you can't see the A because of the  $H_2S$

DIFFERENTIAL AGENT: glucose, lactose, sucrose, and sodium thiosulfate

INDICATOR: phenol red and ferrous ammonium sulfate

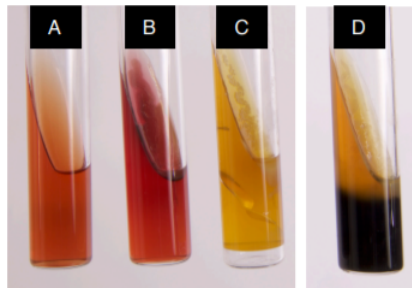

#### UREA BROTH:

Tests the ability of an organism to hydrolyze urea to ammonia and carbon dioxide using the enzyme urease. The broth contains urea and a very small amount of nutrients for the bacteria. The pH indicator is phenol red. If the urea in the broth is degraded and ammonia is produced, the pH rises and the media turns pink.

#### BACTERIAL UNKNOWN IDENTIFICATION:

You must work independently on this project! You will receive no help in staining, performing tests, interpreting tests, or even focusing the microscope other than your lab notebook and your flowchart. There should be NO conversations between students about their unknown experiment. You CAN NOT take pictures. I reserve the right to penalize students for giving or receiving unauthorized help from other students.

Each student will receive a broth culture of their unknown bacteria. The tube will be marked with a number only. Record this number and write it on all plates and tubes that you inoculate, along with your name and the date.

- Your unknown sample will contain 1 bacterial species.
- Do not discard any test results!
- You must request the media that you need from the instructor do not take anything without asking.

#### UNKNOWN LAB DAY 1:

- Gram stain your culture and record the results on DATA SHEET, and turn in your data sheet to the instructor (you will receive this document back at the beginning of day 2).
- Streak for isolated colonies on a TSA plate → this is a skills test.
- Streak for isolated colonies on a MAC.
- Store the original numbered unknown culture in your lab section's rack at the front of the class.

#### UNKNOWN LAB DAY 2:

- Record the results of your MAC on DATA SHEET #1.
  - Inoculate your chosen biochemical tests.
  - You get 3 groups of tests for free from the list below. After that, each test will result in the loss of 5 points.
1. EXO-ENZYMES (CASEIN AND TRYBUTERIN AND GEL)
  2. DECARBOXYLATE (LYSINE AND ORNITHINE)
  3. PHENOL RED BROTHS (GLUCOSE, LACTOSE, SUCROSE)
  4. OXIDASE
  5. TSI
  6. NITRATE
  7. UREA
  8. CITRATE
  9. MR-VP
  10. SIM

#### UNKNOWN LAB DAY 3:

- Record your test results on your DATA SHEET.
- Identify the GENUS and SPECIES of your unknown bacteria.
- Turn in DATA SHEET.

---

This page titled [Lab 11: Biochemical Tests \(Day 2\)](#) is shared under a [CC BY-SA](#) license and was authored, remixed, and/or curated by [Nazy Pakpour & Sharon Horgan](#).

## Lab 11: Data Sheet

Name: \_\_\_\_\_

Section: \_\_\_\_\_

Student ID#: \_\_\_\_\_



GRAM STAIN = 5 POINTS

gram: \_\_\_\_\_  
\_\_\_\_\_

shape: \_\_\_\_\_  
\_\_\_\_\_

arrangement: \_\_\_\_\_  
\_\_\_\_\_

### mac plate (5 pts)

Results: \_\_\_\_\_  
\_\_\_\_\_

Interpretation: \_\_\_\_\_  
\_\_\_\_\_  
\_\_\_\_\_  
\_\_\_\_\_  
\_\_\_\_\_

### TEST#1 \_\_\_\_\_ (10 pts)

Results: \_\_\_\_\_  
\_\_\_\_\_

Interpretation: \_\_\_\_\_  
\_\_\_\_\_  
\_\_\_\_\_  
\_\_\_\_\_  
\_\_\_\_\_

### TEST#2 \_\_\_\_\_ (10 pts)

Results: \_\_\_\_\_  
\_\_\_\_\_

Interpretation: \_\_\_\_\_  
\_\_\_\_\_  
\_\_\_\_\_  
\_\_\_\_\_  
\_\_\_\_\_

TEST#3 \_\_\_\_\_ (10 pts)

Results: \_\_\_\_\_  
\_\_\_\_\_

Interpretation: \_\_\_\_\_  
\_\_\_\_\_  
\_\_\_\_\_  
\_\_\_\_\_  
\_\_\_\_\_

Unknown # \_\_\_\_\_

UNKNOWN BACTERIA (10 pts) \_\_\_\_\_

---

This page titled [Lab 11: Data Sheet](#) is shared under a [CC BY-SA](#) license and was authored, remixed, and/or curated by [Nazzy Pakpour & Sharon Horgan](#).

## Lab 12: Staphylococcus and Streptococcus

### DAY 1:

#### How do we identify gram-positive Staphylococcus and Streptococcus bacteria?

In this lab we will conduct experiments to identify the following species:

- *Staphylococcus aureus*: the most pathogenic for humans; can cause skin infections and food poisoning but is also found in microbiota of nasopharynx
- *Staphylococcus epidermidis*: part of the normal flora of our skin but can cause opportunistic infections
- *Staphylococcus saprophyticus*: causes urinary tract infections
- *Staphylococcus simulans*: part of the normal flora of our skin but can cause opportunistic infections
- *Streptococcus pyogenes*: can be found on human skin and can cause various infections (sore throat, skin)
- *Streptococcus pneumoniae*: found in microbiota of nasopharynx, can cause pneumonia and meningitis
- *Streptococcus agalactiae*: found in microbiota of gastrointestinal and genitourinary tract, can cause neonatal infections

#### MANNITOL SALT AGAR PLATE (MSA)



Selective for gram-positive bacterium (e.g. *Staphylococcus*). Mannitol fermentation by pathogenic staphylococci, such as *S. aureus* and *S. simulans*, is indicated by the agar media changing from red to yellow.

SELECTIVE AGENT: NaCl (salt)

DIFFERENTIAL AGENT: mannitol sugar fermentation

INDICATOR: Phenol red

#### ISOLATE BACTERIA FROM YOUR NOSE:

In this lab, you will be asked to isolate various species of bacteria from different parts of your body. Subsequent biochemical testing will demonstrate the variability seen among the microbiota of your body. In this session, you will isolate *Staphylococci* bacteria from your nose and *Streptococcus* from your throat.

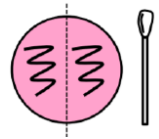

1. Working with your lab partner collect two MSA plates (plate 1 for nose samples, plate two for provided bacterial species)
2. Use a sterile cotton tipped swab to collect a sample DEEP in your nose.
3. Aseptically streak your nose sample (NOT SFIC, NOT LAWN) on your half of the first MSA plate. Incubate at 37°C
4. Using a loop, aseptically streak (NOT SFIC, NOT LAWN) the provided three bacterial species on MSA plate #2. Incubate at 37°C.

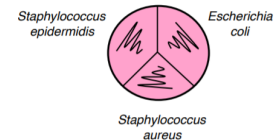

#### Note

You will be comparing the growth between the three sections so make sure your streaks are of equal size.

#### BLOOD AGAR PLATE (BAP)



Nutrient-rich; used for recovery of bacteria and fungi from samples and can determine hemolytic patterns. Our plates are made with sheep's blood.

SELECTIVE AGENT: none

DIFFERENTIAL AGENT: hemolysis (ability to digest/breakdown RBCs)

α-hemolysis will only cause partial lysis of the red blood cells and will appear greenish brown with no halo. Alpha hemolysis is caused by hydrogen peroxide produced by the bacteria, oxidizing hemoglobin to green methemoglobin (e.g. *Streptococcus viridans* and *S. pneumoniae*)

$\beta$ -hemolytic activity will show lysis and complete digestion of red blood cell contents surrounding the colony, most are pathogenic (e.g. *Streptococcus pyogenes*)  
 $\gamma$ -hemolysis is non-hemolytic (*Streptococcus salivarius*)

6. Collect a single BAP plate.

7. Divide a BAP plate into half. Using a sterile swab, collect a sample from your partner's throat and aseptically streak on one side of the plate.

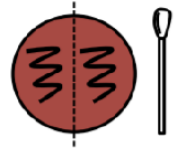

8. Your partner will then collect a sample from your throat and aseptically streak it on to the other side of the plate. Incubate at 37°C.

THE FOLLOWING PORTION YOU WILL DO AS A TABLE:

9. Divide three BAP plates in half and using a sterile swab aseptically make a lawn of the bacterial species on each side as pictured below.

10. Place the appropriate antibiotic disc on each plate. Incubate at 37°C.

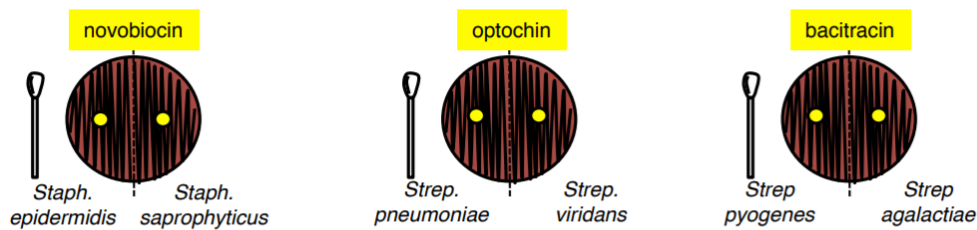

11. Using a loop, aseptically streak (NOT SFIC, NOT LAWN) the provided three bacterial species on a blood agar plate. Incubate at 37°C.

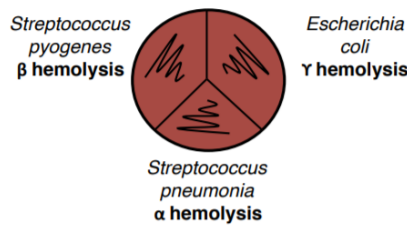

**CAMP TEST**

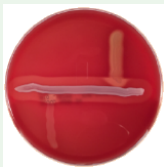

Used to differentiate *Streptococcus agalactiae* CAMP-positive from *Streptococcus pyogenes* CAMP-negative. The  $\beta$ -lysin produced by  $\beta$ -hemolytic *Staphylococcus aureus* acts synergistically with *Streptococcus agalactiae* to create enhanced hemolysis in the region between the two cultures. The synergistic zone is not observed in other *Streptococcus*.

**CAMP TEST:**

12. Make sure you label each of your streaks on your BAP plate for the CAMP test. The bacteria that you will need for this assay are on a rack at the front of each table. With a loop, streak *Staphylococcus aureus* in a straight line down the center of a BAP plate.

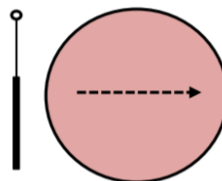

13. With a loop, streak *Streptococcus agalactiae* as a control perpendicularly to *S. aureus* streak but do not touch.

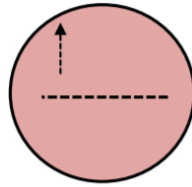

14. With a loop, streak *Streptococcus pyogenes* on the other side in a similar manner and incubate at 37°C (no CO<sub>2</sub>).

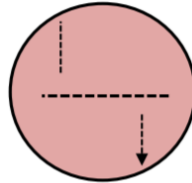

DAY 2:

**RABBIT PLASMA TEST**

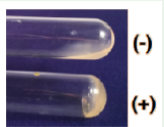

It is used to distinguish between pathogenic and nonpathogenic members of *Staphylococcus*. The exoenzyme coagulase enables the conversion of fibrinogen to fibrin to form an insoluble clot. *Staphylococcus aureus* is usually coagulase-positive. Coagulase is tightly bound to the surface of the *S. aureus* and can coat its surface with fibrin upon contact with blood. The fibrin clot protects the bacterium from phagocytosis and other defenses of the host. An *S. aureus* infection of the blood, if left untreated, will result in death.

1. Working with your lab partner(s), record your results for your BAP, MSA, and CAMP plates on your worksheet.
2. Get TWO coagulase test tubes.
3. Aseptically inoculate the test tube with EITHER of the following:
  - an extra large loopful of your nose sample (YELLOW COLONIES ONLY!)
  - Bacteria A from the plate provided to you
4. Aseptically inoculate your other test tube with
  - Bacteria B from the plate provided to you
5. Gently mix and incubate at 37°C.

**HARDY StaphTEX BLUE KIT:**

5. Label three of the reaction circles from the HARDY StaphTEX Blue Kit as +, -, and ?
6. Invert and mix the latex reagent from the HARDY StaphTEX Blue Kit.
7. Squeeze 1 drop of the re-suspended latex reagent onto 3 of the reaction circles on the slide-card.
8. Add one drop of the positive control onto another circle. Add one drop of the negative control onto another circle WITHOUT THE DROPS TOUCHING.

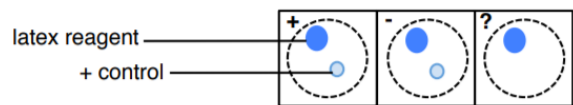

9. Using a wooden applicator stick, apply the same bacteria you used in step 3 into the (?) reaction circle and mix.

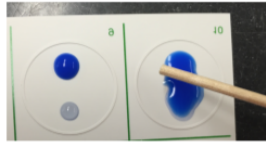

10. Using a separate wooden stick, mix the reagents within the (+) and (-) reaction circle GENTLY! Make sure to spread the mixture out to cover most of the circle as it will make the reaction easier to see.
11. Gently hand rock the slide-card for 20 seconds to agitate the mixture (avoid spilling onto other reaction circles). Record your results on your worksheet.

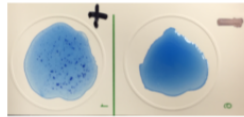

### widal test

*Salmonella typhi* causes typhoid fever while *Salmonella paratyphi* causes a milder form of the disease. French bacteriologist George Widal (1862-1929) developed the Widal test to differentiate the two. The Widal test is a serological test that utilizes a suspension of killed *Salmonella typhi* as an antigen to detect the presence of anti-*Salmonella typhi* antibodies in a patient's serum. Although the use of the Widal test in developed countries has waned, it still used a diagnostic tool in developing countries.

Antibody titers are low during the 1<sup>st</sup> week of infection with both bacteria and slowly rise over time. Infections with any other gram-negative bacteria may yield a false positive result due to cross-reactivity. To allow for the confidence of diagnosis, patient tests are submitted in paired serum samples (1st test done early and 2nd test done 2 weeks later).

### WIDAL TEST:

12. Label 8 conical tubes 1:20, 1:40, 1:80, 1:160, 1:320, 1:640, 1:1280, and negative control.
13. Add 500  $\mu$ l of sterile saline to each tube using a pipetter.
14. Obtain a 1:10 dilution of serum (patient sample which contains antibodies) from your instructor.
15. Add 500  $\mu$ l of patient serum to the 1:20 tube, finger vortex.
16. Take 500  $\mu$ l from the 1:20 tube and pipette into the 1:40 tube, finger vortex.
17. Take 500  $\mu$ l from the 1:40 tube and pipette into the 1:80 tube, finger vortex.
18. Take 500  $\mu$ l from the 1:80 tube and pipette into the 1:160 tube, finger vortex.
19. Take 500  $\mu$ l from the 1:160 tube and pipette into the 1:320 tube, finger vortex.
20. Take 500  $\mu$ l from the 1:320 tube and pipette into the 1:640 tube, finger vortex.
21. Take 500  $\mu$ l from the 1:640 tube and pipette into the 1:1280 tube, finger vortex.
22. Take 500  $\mu$ l from the 1:1280 tube and discard.
23. Add 500  $\mu$ l of heat-killed HD *S. typhi* flagella antigen to every tube, INCLUDING the original 1:10 dilution of the patient serum and the negative control.
24. Incubate at 50°C water bath.

This page titled [Lab 12: Staphylococcus and Streptococcus](#) is shared under a [CC BY-SA](#) license and was authored, remixed, and/or curated by [Nazy Pakpour & Sharon Horgan](#).

## Lab 12: Worksheet

Name: \_\_\_\_\_

Section: \_\_\_\_\_

Student ID#: \_\_\_\_\_

Work in groups on these problems. You should try to answer the questions without referring to your textbook. If you get stuck, try asking another group for help.

1. Draw your MSA plate results IN COLOR here (1 pt).

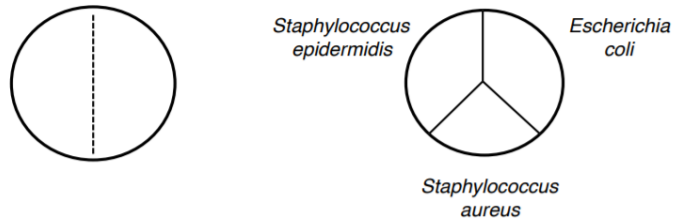

2. Why did *Escherichia coli* not grow on the MSA plate (1 pt)?

3. What do you expect will be the result of the coagulase test for the bacterial species you chose? Why? (2 pts)

4. Fill in the chart below (1 pts):

	HEMOLYSIS ( $\alpha$ / $\beta$ / $\gamma$ )	NOVOBIOCIN susceptible/ resistant	OPTOCHIN susceptible/ resistant	BACITRACIN susceptible/ resistant
<i>Staphylococcus epidermidis</i>			X	X
<i>Staphylococcus saprophyticus</i>			X	X
<i>Streptococcus pneumoniae</i>		X		X
<i>Streptococcus viridans</i>		X		X
<i>Streptococcus pyogenes</i>		X	X	
<i>Streptococcus agalactiae</i>		X	X	

5. How does having the exo-enzyme coagulase make the bacteria more pathogenic? (1 pts)

6. Record your results for the StaphTEX kit (1 pt)

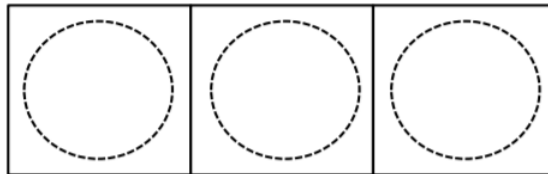

7. Draw your CAMP plate below, making sure to label each species of bacteria and showing the areas of hemolysis. (1 pt)

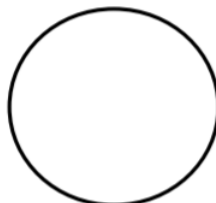

8. On the CAMP plate, where was enhanced hemolysis observed and why? (2 pts)

---

This page titled [Lab 12: Worksheet](#) is shared under a [CC BY-SA](#) license and was authored, remixed, and/or curated by [Nazy Pakpour & Sharon Horgan](#).

## Lab 13: ELISA

### ELISA:

1. Record results of Widal test using + or - signs:

- extremely agglutinated (+++)
- very agglutinated (++)
- a little agglutinated (+)
- no agglutination (-)

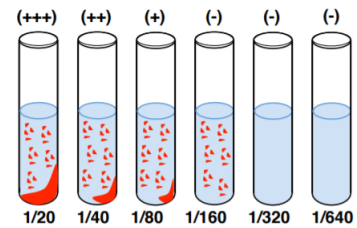

2. Positive results should lead to agglutination (clumping) of antibody to antigen. Your titer is the lowest dilution that had a positive result. **CIRCLE YOUR TITER BELOW.**

Dilution	1:20	1:40	1:80	1:160	1:320	1:640

### ELISA: enzyme-linked immunosorbent assay

ELISA is a plate-based assay technique designed for detecting and quantifying substances such as peptides, proteins, antibodies, and hormones using antibodies and color changes. ELISA is a common medical and research lab technique.

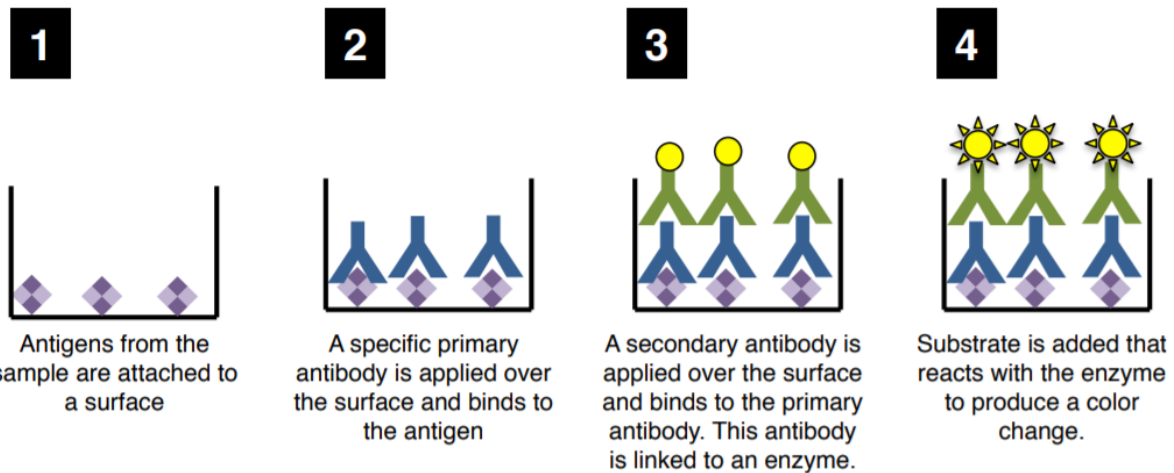

This page titled [Lab 13: ELISA](#) is shared under a [CC BY-SA](#) license and was authored, remixed, and/or curated by [Nazy Pakpour & Sharon Horgan](#).

## Lab 13: Worksheet

---

Name: \_\_\_\_\_

Section: \_\_\_\_\_

Student ID#: \_\_\_\_\_

Work in groups on these problems. You should try to answer the questions without referring to your textbook. If you get stuck, try asking another group for help.

1. Why do we do the washes between each step? (1)
  2. If your positive control doesn't work what might have happened? (1)
  3. What would the plate look like if your negative control did not work? (1)
  4. What information does the positive control give us? What information does the negative control give us? (1)
  5. Why does the secondary antibody stick to the primary antibody and not the antigen? (1)
- 

This page titled [Lab 13: Worksheet](#) is shared under a [CC BY-SA](#) license and was authored, remixed, and/or curated by [Nazzy Pakpour & Sharon Horgan](#).

## Index

---

### A

aseptic technique

[Lab 2: Aseptic Technique](#)

### C

carbol fuchsin

[Lab 4: Acid-Fast, Spores, and Capsule Stains](#)

catalase test

[Lab 11: Biochemical Tests \(Day 2\)](#)

Coliform colonies

[Lab 8: Membrane Filtration](#)

### E

ELISA

[Lab 13: ELISA](#)

Endo agar

[Lab 8: Membrane Filtration](#)

Endospore Staining

[Lab 4: Acid-Fast, Spores, and Capsule Stains](#)

### F

fecal contamination

[Lab 8: Membrane Filtration](#)

### G

germicides

[Lab 7: Sterilization](#)

Gram staining

[Lab 3: Simple, Negative, and Gram Stain](#)

### M

McFarland standards

[Lab 6: Antibiotic Susceptibility Testing](#)

### N

Nigrosin

[Lab 3: Simple, Negative, and Gram Stain](#)

### O

oxidase test

[Lab 11: Biochemical Tests \(Day 2\)](#)

### P

Pipette

[Lab 5: Pipette and Environmental Requirements](#)

### S

sterilization

[Lab 7: Sterilization](#)

### T

Trypticase soy agar

[Lab 1: The Microscopic World](#)

## Glossary

---

**Sample Word 1** | Sample Definition 1

## Detailed Licensing

---

### Overview

**Title:** Book: General Microbiology Lab Manual (Pakpour & Horgan)

**Webpages:** 38

**All licenses found:**

- [CC BY-SA 4.0](#): 76.3% (29 pages)
- [Undeclared](#): 23.7% (9 pages)

### By Page

- [Book: General Microbiology Lab Manual \(Pakpour & Horgan\) - CC BY-SA 4.0](#)
  - [Front Matter - Undeclared](#)
    - [TitlePage - Undeclared](#)
    - [InfoPage - Undeclared](#)
    - [Table of Contents - Undeclared](#)
    - [Licensing - Undeclared](#)
  - [Introduction - CC BY-SA 4.0](#)
  - [Lab 1: The Microscopic World - CC BY-SA 4.0](#)
    - [Lab 1: Worksheet - CC BY-SA 4.0](#)
  - [Lab 2: Aseptic Technique - CC BY-SA 4.0](#)
    - [Lab 2: Worksheet - CC BY-SA 4.0](#)
  - [Lab 3: Simple, Negative, and Gram Stain - CC BY-SA 4.0](#)
    - [Lab 3: Worksheet - CC BY-SA 4.0](#)
  - [Lab 4: Acid-Fast, Spores, and Capsule Stains - CC BY-SA 4.0](#)
    - [Lab 4: Worksheet - CC BY-SA 4.0](#)
  - [Lab 5: Pipette and Environmental Requirements - CC BY-SA 4.0](#)
    - [Lab 5: Worksheet - CC BY-SA 4.0](#)
  - [Lab 6: Antibiotic Susceptibility Testing - CC BY-SA 4.0](#)
    - [Lab 6: Worksheet - CC BY-SA 4.0](#)
  - [Lab 7: Sterilization - CC BY-SA 4.0](#)
    - [Lab 7: Worksheet - CC BY-SA 4.0](#)
  - [Lab 8: Membrane Filtration - CC BY-SA 4.0](#)
    - [Lab 8: Worksheet - CC BY-SA 4.0](#)
  - [Lab 9: Standard Plate Count - CC BY-SA 4.0](#)
    - [Lab 9: Worksheet - CC BY-SA 4.0](#)
  - [Lab 10: Plaque Assay and Biochemical Tests \(Day 1\) - CC BY-SA 4.0](#)
    - [Lab 10: Worksheet - CC BY-SA 4.0](#)
  - [Lab 11: Biochemical Tests \(Day 2\) - CC BY-SA 4.0](#)
    - [Lab 11: Data Sheet - CC BY-SA 4.0](#)
  - [Lab 12: Staphylococcus and Streptococcus - CC BY-SA 4.0](#)
    - [Lab 12: Worksheet - CC BY-SA 4.0](#)
  - [Lab 13: ELISA - CC BY-SA 4.0](#)
    - [Lab 13: Worksheet - CC BY-SA 4.0](#)
  - [Laboratory and Safety Rules - CC BY-SA 4.0](#)
  - [Back Matter - Undeclared](#)
    - [Index - Undeclared](#)
    - [Glossary - Undeclared](#)
    - [Detailed Licensing - Undeclared](#)